

Single and Bi-Parting Manual/Electric Sliding Doors with Automatic Operator (ICC-5)

Installation

R-PLUS

COLD STORAGE DOORS

A Division of Imperial Manufacturing, Inc.

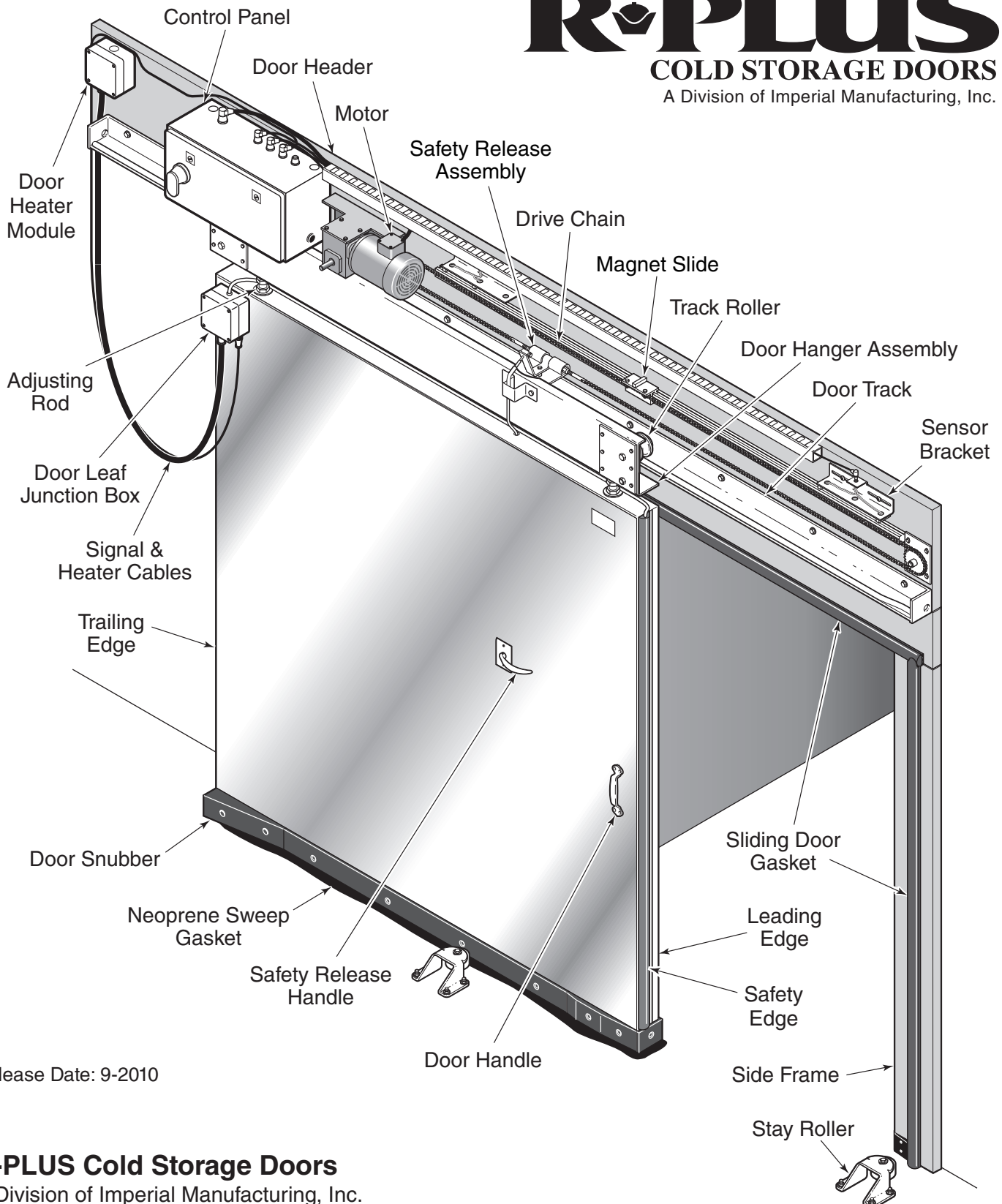

Release Date: 9-2010

R-PLUS Cold Storage Doors

A Division of Imperial Manufacturing, Inc.

2271 NE 194th • Portland, Oregon 97230

Toll Free (800) 238-4093 • Phone (503) 665-5539 • Fax (503) 665-2929 • www.RPlusDoors.com

Table of Contents

	Page
Contents	2
Warnings and Cautions	3
Attaching Door Frames to Wall	4
Joining Door Sections with Cam Locks	5
Assemble and Install Door and Door Hanger	6
Adjusting the Door Height	6
Stay Roller Installation	7
Door Gasket Adjustment	8
Connect the Door Cables	9
Door Signal Cable(s)	
Door Heater Cable(s)	
Verify Door Cable Installation	
Connect the Safety Release	10
Drive Chain Adjustment	10
Install the Door Wiring	11–12
Main Power to the Door	
Door Control Signals	
Pull Cord Installation	
Other Input/Output Signals	
Door Travel Adjustment	13–16
Adjust the Door Open travel limit	
Adjust the Door Close travel limit	
Test the Door travel limits	
Adjust the Door Safety Edge	16
Door Auto-Close Function	17
Door Cycle Counter	17
Periodic Maintenance	18

IMPORTANT

1. **Read all instructions!**
2. Please *review all* illustrations and drawings *before installing* the door.
3. Inspect and report any damage and/or missing parts, before installing. The vendor will *not be responsible for costs* of installing or removing damaged doors.
4. Confirm the *opening* for the door matches the size on the *packing list*.

Warnings and Cautions

We have provided many important safety messages in this manual and the Parts manual about your Sliding Door. Always read and obey all safety messages.



This is the safety alert symbol.

This symbol alerts you to potential hazards that can kill, injure, or damage equipment.

All safety messages will follow the safety alert symbol and either the word “Warning” or “Caution”. These words mean:



WARNING You can be killed or seriously injured if you don't follow instructions.



CAUTION Equipment can be damaged or destroyed if you don't follow instructions.

All safety messages will tell you how to proceed to reduce the chance of death, injury, or damage to the Sliding Door.

Important Safety Instructions

To reduce the risk of fire, electrical shock, injury, death, or damage when installing or repairing the Door, follow basic precautions, including the following:



WARNING: Improper wiring or lack of proper ground can result in fire, electrical shock, injury or death. Disconnect power to the Door before performing any electrical repairs. Field wiring or electrical repair should be done by a licensed professional electrician. Follow all local building codes and laws for electrical installation.



WARNING: Control panel and anti-frost heaters operate on two different circuits. Make sure to turn power off to both circuits prior to servicing the door.



WARNING: All mechanical repairs made to the Sliding Door should be performed by a qualified service technician familiar with this type of door.



WARNING: Remove children and unnecessary adults from the area when installing or servicing the Door.



WARNING: Always keep your hands clear of the drive chain and other moving parts when door is powered or when it is to be moved manually. Avoid loose fitting or hanging clothing. An electric door can start moving automatically, such as when the auto-close timer is activated.



WARNING: In case of electrical fire, disconnect the power supply. Do not use water on electrical fires. Smother the fire with an extinguisher rated for C-class fires.



CAUTION: After changing any parts on the Door, always check that door tightness, anti-jump devices and safety edge sensors are adjusted and working properly.



CAUTION: Per NEC 300-7, all raceways passing from different temperatures shall be sealed with putty or other method to stop the travel of moisture. Furthermore, all junction box covers plates shall be sealed. Verify these seals are in place and functioning properly after performing any service on the Door.

Attaching Door Frames to Wall

1. Verify that the door opening and wall are plumb, and the opening is square. Adjust as necessary.
2. Before installing the door frame, check for proper backing in the wall. See Figure 1.

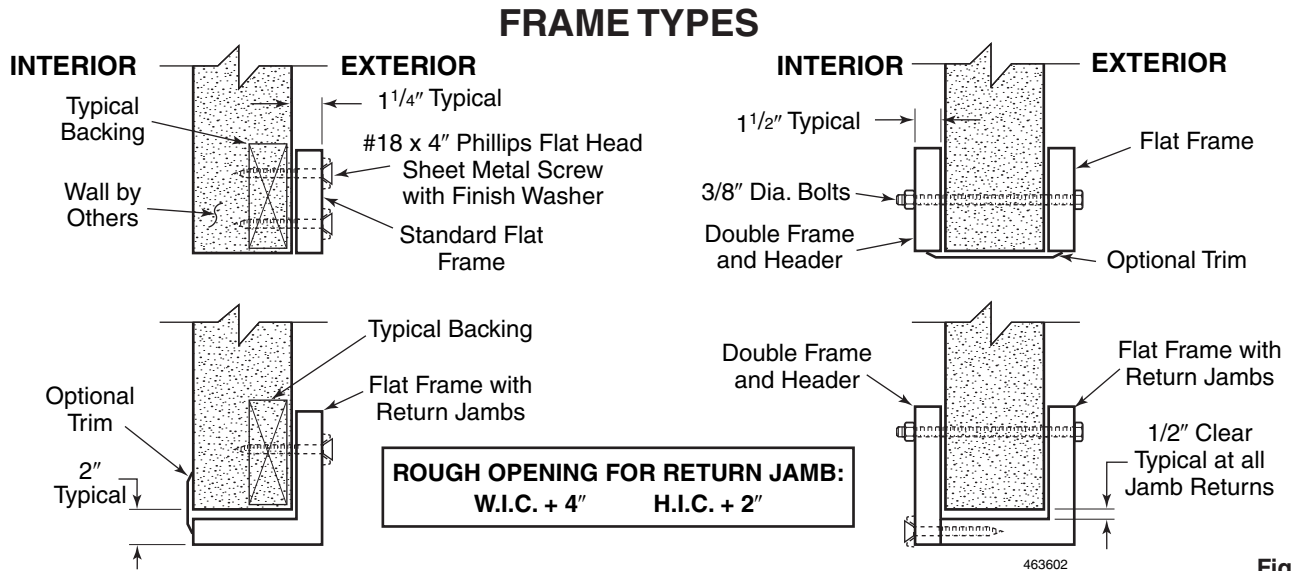

Figure 1

3. At job site, drill 5/16" holes in the frames and headers for mounting to the backing in the wall. Space holes 6" in from the end, then every 36". See Figure 2.
4. Stand the left and right frames up against the wall, one on each side of the door opening so they are located correctly. Check to see that the frames are plumb and square to the door opening.

NOTE: When installing a freezer door, a thermal break is required. Add *Silicone caulking* behind the side frames and Header Assembly before fastening to the wall.

Attach the frames to the wall with the #18 x 4" Phillips flat head sheet metal screws and finish washers that are provided. Verify that the frames are still plumb and square to the door opening. See Figure 2.

5. Mount the Sliding Door Track and Header assembly above the door frame. See Figure 3. For a single door, mount the end of the Track flush with the edge of the side frame. For a bi-parting door, the center stops on the Door Track should be centered above the door opening. In all cases, anchor the Door Header with the #18 x 4" Phillips flat head sheet metal screws and finish washers.
6. Seal with *Silicone caulking* around the side frames and header after tightening the screws.

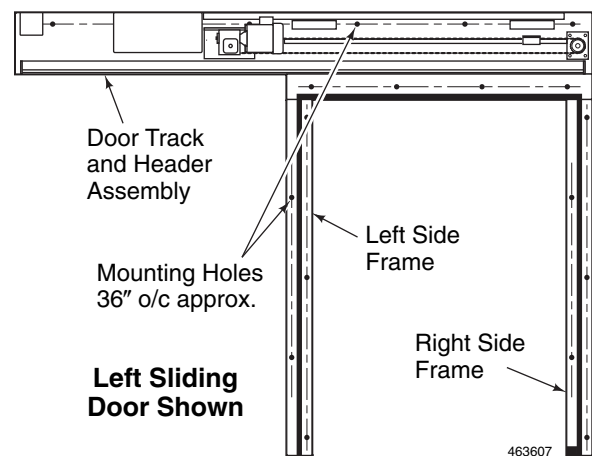

Figure 2

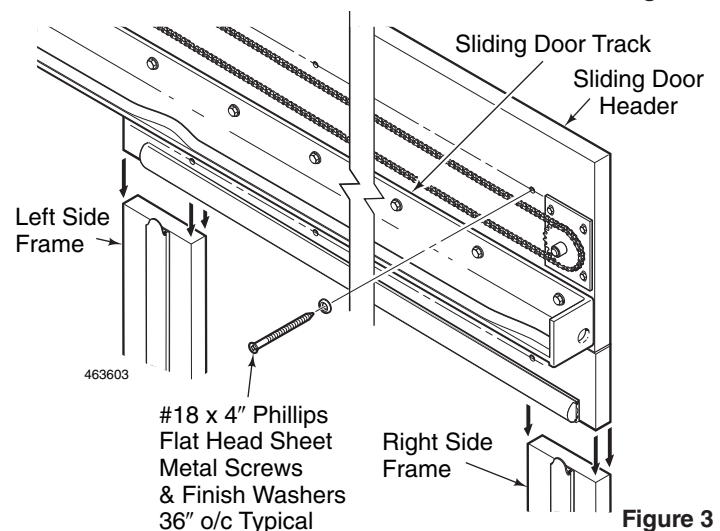

Figure 3

Joining Door Sections with Cam Locks



CAUTION: All parts have been pre-assembled at the factory. No Drilling should be required. Be careful to not overdrive any fasteners.

Doors larger in width must be field assembled as follows:

1. Begin by laying the sections of the door face down on a clean and level surface. Block as needed so the door sections are aligned. See *Figure 4*.
2. Apply silicone caulk to both long edges, then slide the door sections together. Cam lock the sections with a 3/8" hex wrench (supplied). Turn clockwise until the lock is engaged with the Hinging pin. See *Figure 5*.
3. Note that interior and exterior surfaces of the door sections along the joint should be flush and smooth. Install cam hole covers. Add *Silicone caulking* to the seams between the panels on both interior and exterior sides.
4. Remove the Adjuster Rod and Jam Nuts. Install the 10 gauge Metal Plate at the top and the bottom of the door. Anchor the strips with #8 x 1-1/2" Phillips pan head screws that have been provided. Reinstall the Adjuster Rod. See *Figure 6*.

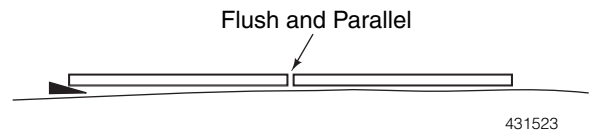

Figure 4

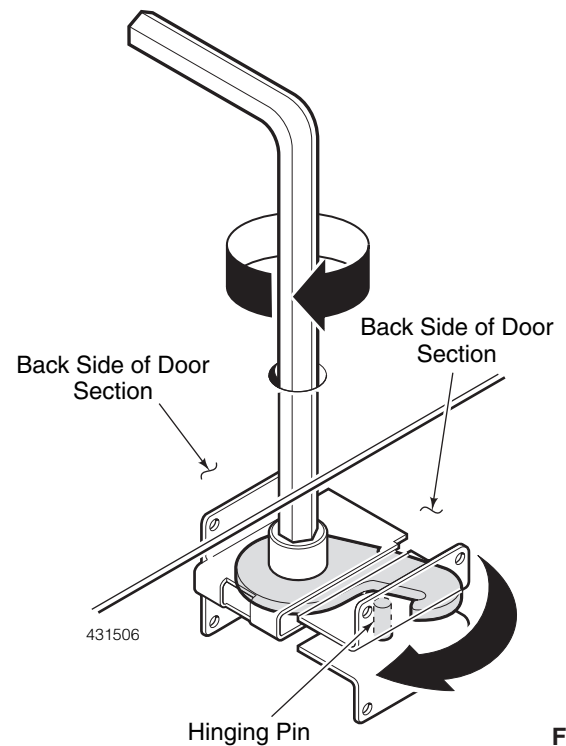

Figure 5

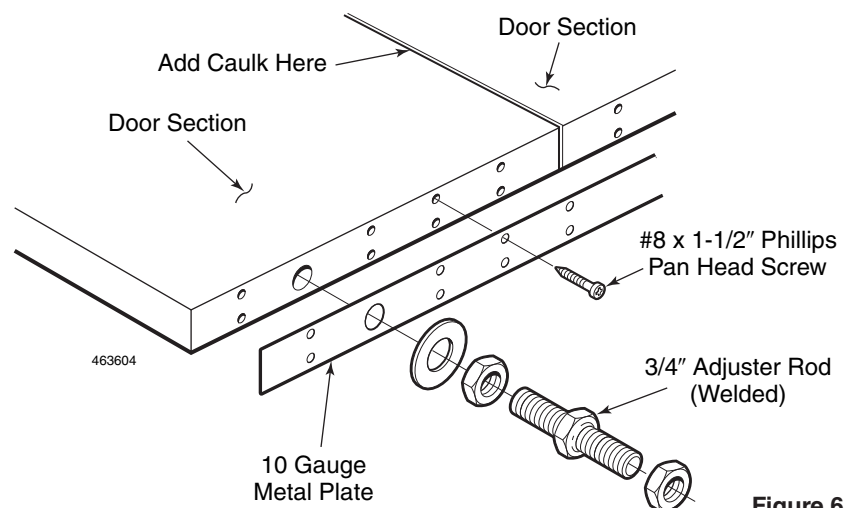

Figure 6

Assemble and Install Door and Door Hanger

1. Install the Door Hanger on top of the door. Fasten it to the door with the Square Washers, flat washers, Jam Nuts, nylon Lock Nuts, and 3/4" Adjuster Rods. Make sure the Adjuster Rod comes through the nylon Lock Nut on the Square Washer no more than 1/16". Adjust the Door Hanger temporarily to 3-3/4" from the top of the door to the bottom of the Channel. Final adjustment is made after the Door is hanging on the Door Track. See Figure 7.
2. Place the door section next to the door opening and lean it against the steel Door Track. Be careful to not damage the Sweep Gasket at the bottom of the door section.
3. Lift the door and place the Track Rollers on the Round Welded Rod of the Door Track.
4. Install the Anti-Jump Bolt or Anti-Jump Roller to keep the door on the track. Adjust to a gap of 1/8". See Figure 8.

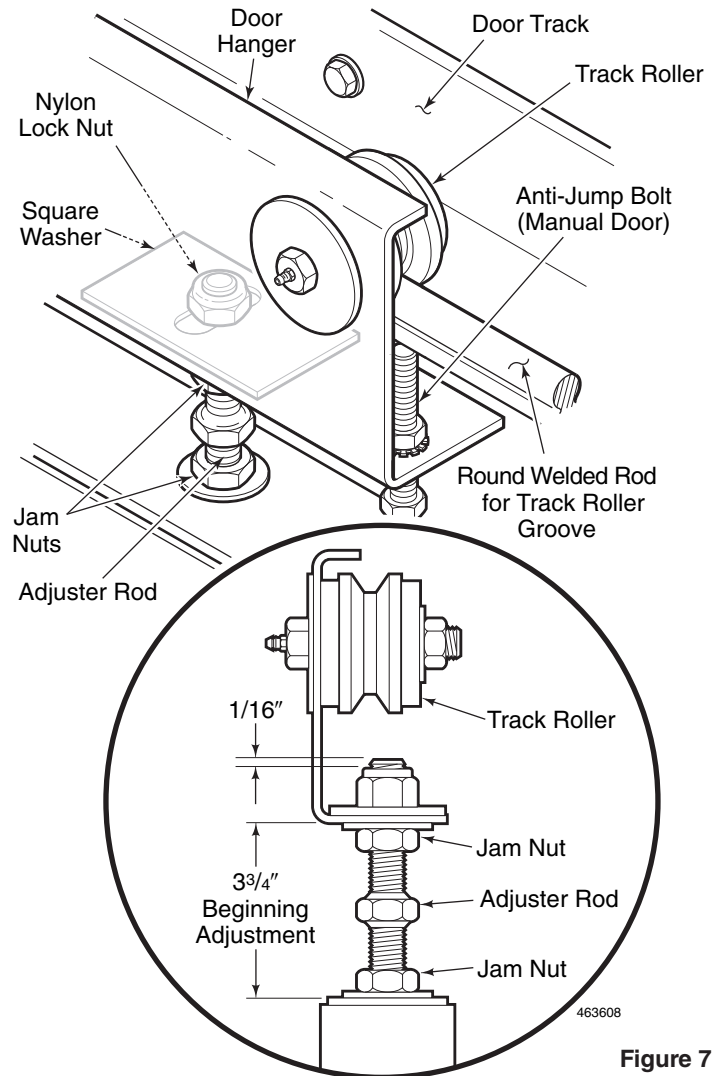

Figure 7

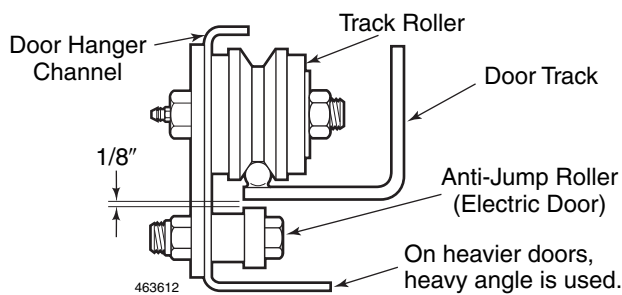

Figure 8

Adjusting the Door Height

The Sweep Gasket should lift free of the floor when the Door is opened.

1. For a single slide door, set the door in the closed position and adjust the door height so the Sweep Gasket lightly touches the floor and the door lines up with the side frames. See Figure 9. To adjust the height, loosen both the top and bottom Jam Nuts and raise or lower the door with the welded nut on the Adjuster Rod. Tighten the Jam Nuts to lock the door in position. See Figure 7.
2. For a bi-parting door, set the doors in the closed position and adjust the door height so the Sweep Gasket lightly touches the floor. Use the Adjuster Rod to align the two door leaf sections for a proper seal where the doors come together. The door leaves should be parallel and have a uniform seal from top to bottom. See Figure 9. To adjust the height, loosen both the top and bottom Jam Nuts and raise or lower the door leaf with the Adjuster Rod. Tighten the Jam Nuts to lock the door in position. See Figure 7.

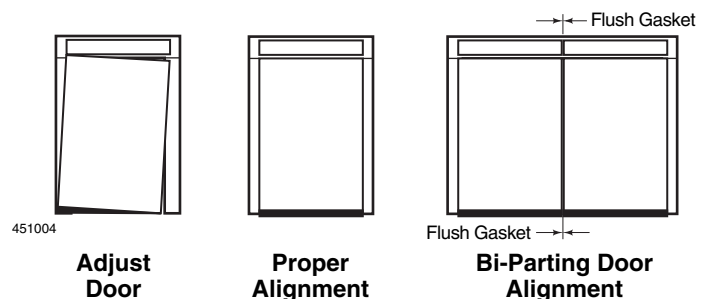

Figure 9

Stay Roller Installation

1. The purpose of the Stay Roller is to keep the bottom of the door against the gaskets in the closed position and to keep the door from kicking out at the bottom when moving.
2. If not found in the hardware box, the Stay Roller assemblies are secured to a piece of wood located on the front side of the Door Header. Remove them for installation. See Figure 10.
3. Be sure each Stay Roller Lock Nut is centered in the adjustment slot. Note the distance from the wall for *your* door size and type. See Figure 11. With Bi-Parting door(s) fully closed, position the center of the Trailing Edge Stay Roller 3/4" in from the end of the Door Snubber Wedge. For Single Slide Doors, center the Leading Edge Stay Roller on the flat spot on the Door Snubber.
4. Use four 3/8" x 2-3/4" concrete wedge anchors to fasten each Stay Roller to the floor. See Figure 12.

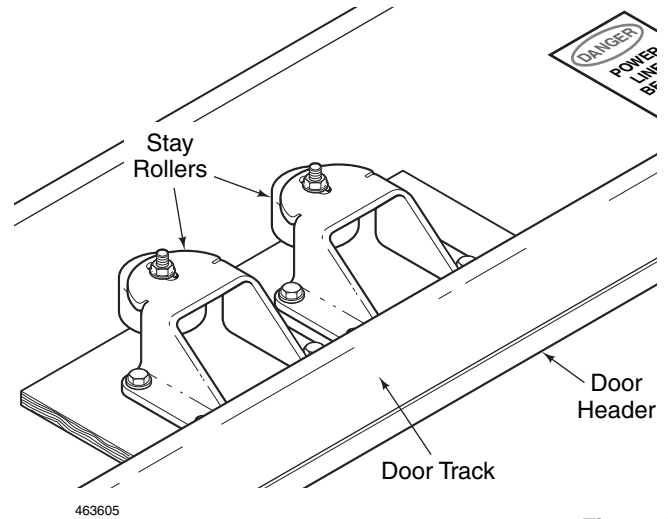

Figure 10

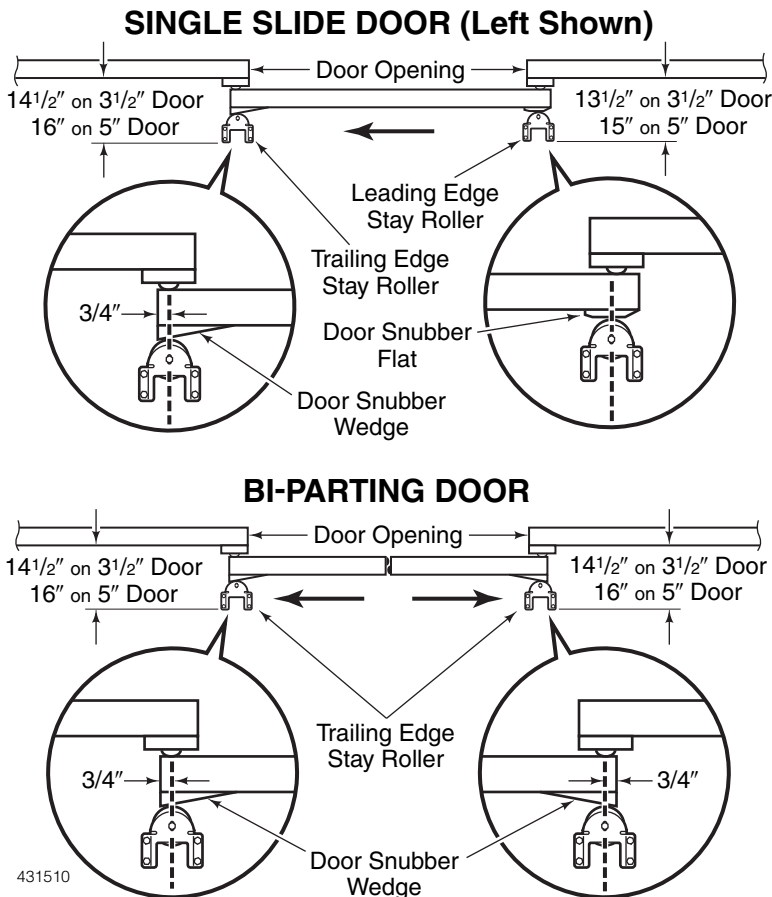

Figure 11

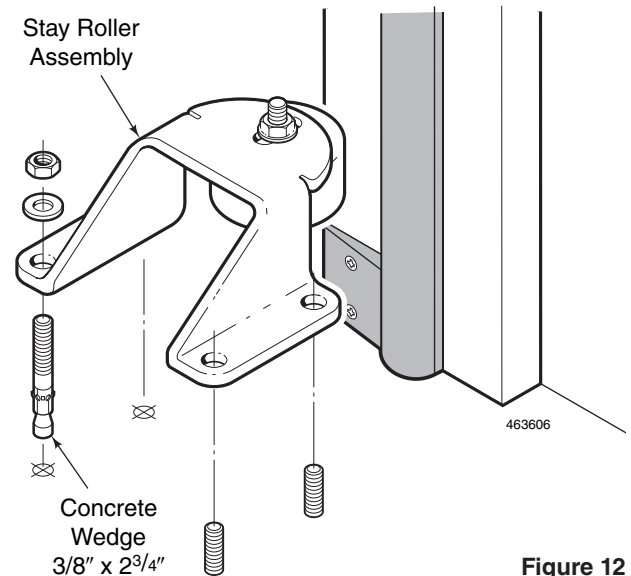

Figure 12

Door Gasket Adjustment

1. With the door in the closed position, the gasket should be compressed 1/8". Check the gasket at the four corners of the door for proper compression. See Figure 13.

CAUTION: Do not adjust the door so tight that it becomes hard to open. If electric doors are adjusted too tight, the motor drive will fault while opening the door.

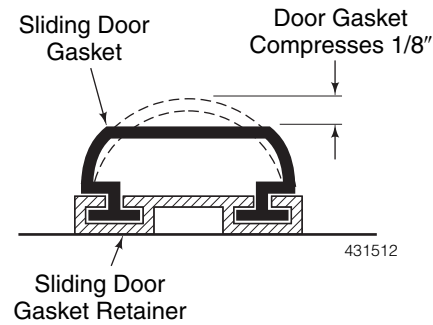

Figure 13

2. To adjust the gasket compression at the top of the door, loosen the top Jam Nut and push the door in until the gasket is properly compressed. Lock the door in place by tightening the top Jam Nut. See Figure 14.

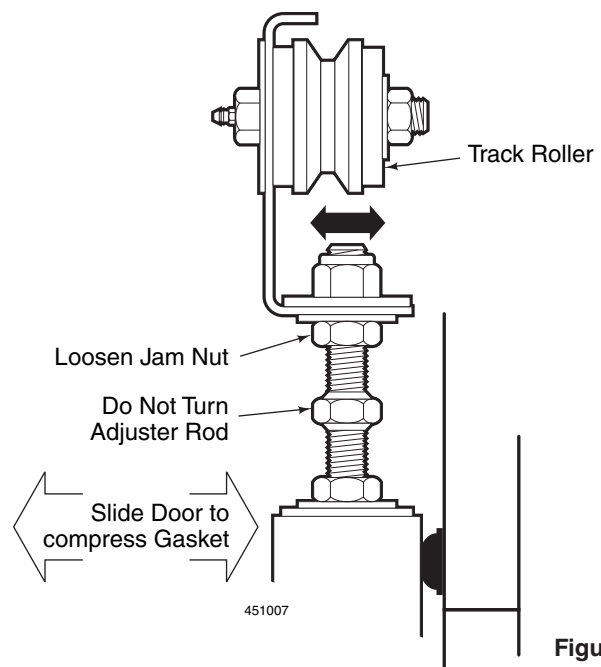

Figure 14

3. To adjust the gasket compression along the side frames, loosen the Lock Nut securing the UHMW Stay Roller to the Floor Bracket. Move the Stay Roller in the slotted hole until proper gasket compression is achieved. Tighten the Lock Nut to secure the Roller in position. On a Single Slide door, adjust the trailing edge first, then the leading edge. See Figure 15.
4. After the door has been hung and the gaskets have been adjusted for compression, go inside the room, close the door, and check all four sides for proper seal. Make sure no daylight is coming through. Check the center if you have a bi-parting door.

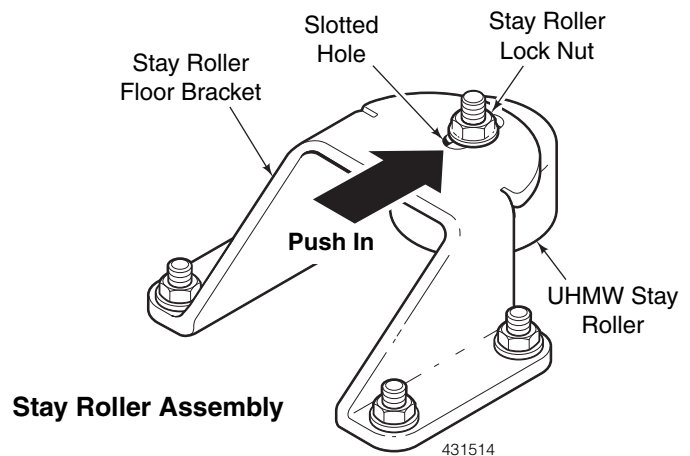

Figure 15

Connect the Door Cables

The Signal Cable(s) (thin cable) and the thicker Heater Cable (if equipped) are attached to the Control Panel and Door Header when shipped.

Door Signal Cable(s)



CAUTION: The cables are mated. Do not force the cable plugs into the receptacles. Align the plug with the receptacle and insert the plug until it bottoms — twist the locking ring clockwise, by hand, until it locks.

Single Sliding Doors only. Connect the 8-pin Signal Cable (thin cable) to the corresponding receptacle on the Door Leaf Junction Box. See Figure 16.

Bi-Parting Doors only. Connect the 8-pin Signal Cable (thin cable) twist plug to the corresponding receptacle on the Door Master Leaf Junction Box. In a similar fashion as above, connect the 4-pin Signal Cable (thin cable) to the Junction Box on the Door Slave Leaf. See Figure 16.

Door Heater Cable(s)

Freezer doors are equipped with a Door Heater Module mounted on the Door Header. Bi-Parting doors have a Door Heater Module mounted on each end of the Door Header. See Figure 16.

1. Switch off the power to the Heat Cable Module(s). Connect the 3-pin Door Heater Cable(s) (thick cable already connected to the Door Heater Module), to the corresponding receptacle(s) on the Door Leaf Junction Box(es). See Figure 16.

Verify the Door Cable Installation

1. Verify after connection that the Door Signal and Door Heater cables have enough slack to move freely and not get stretched tight when the door operates. In the open position, the cable loop from the Door Heater Module(s) on the Header to the Door Leaf Junction Box should extend approximately half way down the door. See Figure 17.
2. Verify that each cable is firmly attached to the end of the Door Track with a zip tie. See Figure 17.

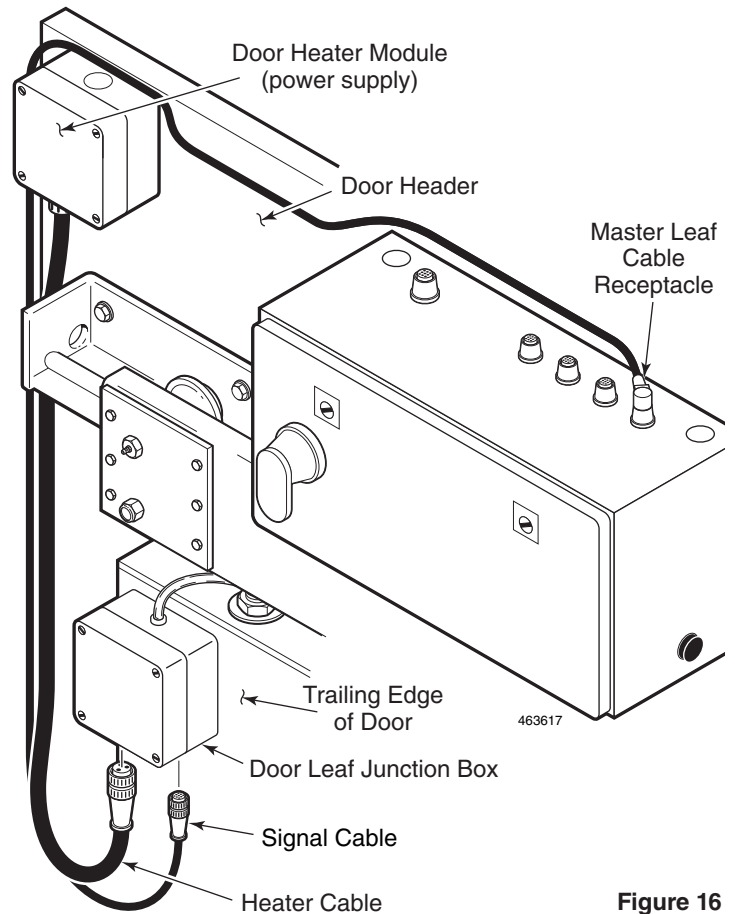

Figure 16

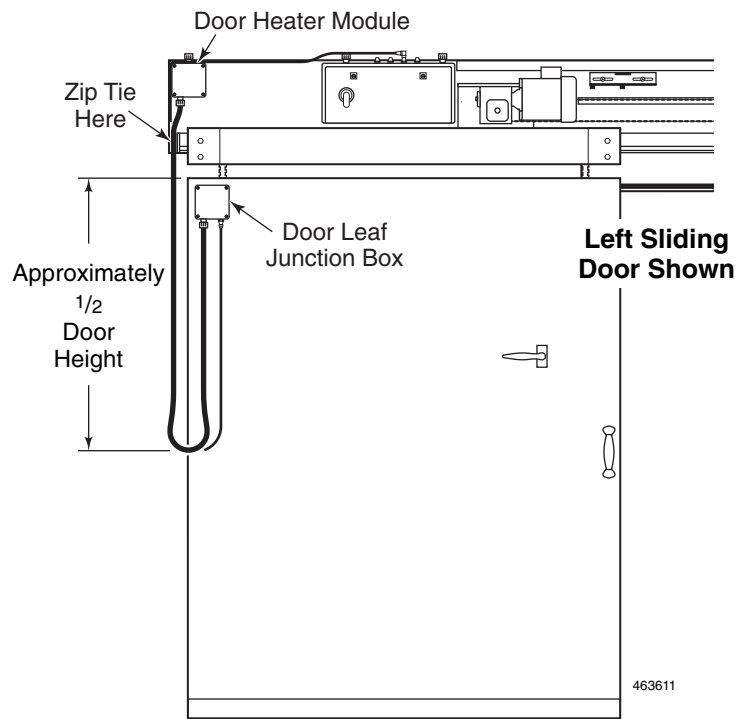

Figure 17

Connect the Safety Release

1. Align the threaded holes in Safety Release Tube and the holes in the Cable Bracket with the pre-drilled holes in the Door Hanger channel. Fasten both securely to the channel with the cap-screws and lockwashers supplied. See *Figure 18*.
2. Feed the Safety Release Cable through the tube in the Cable Bracket. Strip 2" of the covering from the cable; then, slide the cable through the hole in the Release Latch and into the Cable Clamp.
3. The cable should be stretched tight from the Door Release Handle to the Release Latch. The Latch should be at "rest" on the Safety Release Tube and the Door Release should be in the "latched" position. Tighten the setscrew in the Cable Clamp.
4. **For bi-parting doors**, the Slave Leaf is bolted directly to the chain. Slide the Door Bracket into alignment with the Chain Bracket and fasten with the capscrews provided. See *Figure 19*.

NOTE: If door is later adjusted for gasket compression at the floor, the Safety Release Cable and Cable Clamp may need to be readjusted.

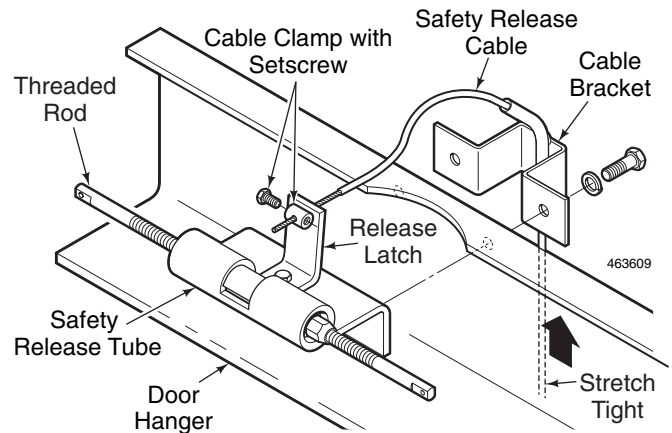

Figure 18

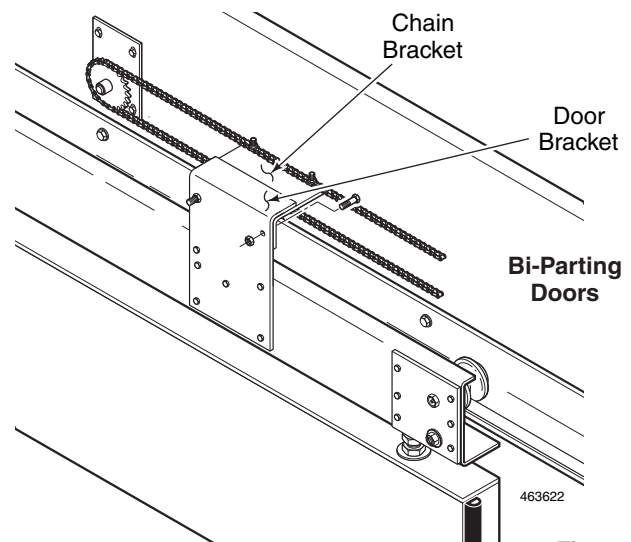

Figure 19

Drive Chain Adjustment

The Drive Chain is pre-adjusted at the factory. If adjustment becomes necessary, at the time of installation or later, it can be accomplished at the Safety Release without disconnecting the Chain. See *Figure 20*.

1. Pull the Safety Release Cable to release the Door from the Drive Chain.
2. Manually slide the door to disengage the Drive Chain Bullet from the Safety Release Tube.
3. Loosen the Lock Nuts on both Threaded Rods.
4. Turn the Drive Chain Bullet clockwise to tighten the Chain. When making a large adjustment, it may be necessary to remove a link from the Chain. This can be done at a Threaded Rod Master Link.
5. When the Drive Chain is properly adjusted, slide the door back to reconnect it to the Chain. The Drive Chain Bullet will automatically engage the Release Latch when the Safety Release Tube and the Bullet align. Move the door sideways until the door catches and free movement stops.

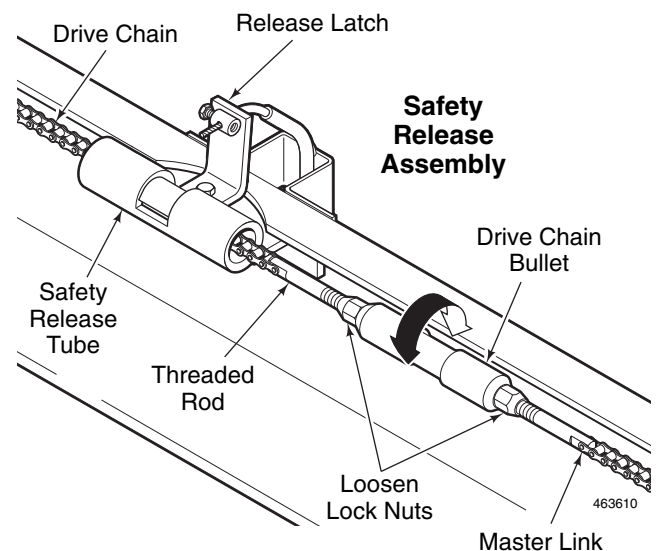

Figure 20

Install the Door Wiring

NOTE: Per NEC 300-7, all raceways passing from different temperatures shall be sealed with putty or other method to stop the travel of moisture.

Main Power to the Door

The main power connects to the circuit breaker located inside the Control Panel, on the left side.

1. Install conduit and wire from the breaker panel to the left side of the control panel. See *Figure 21*.
2. Connect ground wire to the ground terminal.
3. On 3-phase systems, connect each phase to breaker poles 1, 3, and 5. On single phase systems, connect the Phase line to breaker pole #1 and the Neutral line to breaker pole #3 (breaker pole #5 is not used). See *Figure 21*.

NOTE: Power supply wiring to the operator must comply with NEC and all local electrical codes. We recommend using a surge protector.

Door Control Signals

Door control signal wiring is done at the terminal blocks located inside the Control Panel, on the right side. See *Figure 21*. There are many signals used to control the door Operator. The most common are pull cord switches or stations, three button stations (i.e. open, close, stop) and radio control. All three may be used separately, in combination, or all together. The control circuit is 24 VDC. Consult local electrical codes before proceeding with permanent installation.

Pull Cord Installation

Locate the Switches

1. Do not mount the pull cord switch in the air flow of the coils. Air flow will move the cord and activate the switch. If the pull cord switch must be mounted in front of the coils, provide an air baffle (by others) to prevent icing of the switch. The air baffle must be of adequate size to protect the pull cord itself, but not obstruct function of the coils. Consult the cold storage contractor. See *Figure 22*.
2. Mount the pull cord switch to the wall or ceiling using the switch mounting holes or the mounting plate provided. Locate the switches at least 24" from the conduit penetration through the ceiling or wall. See *Figure 23*.



WARNING: Drilling of the pull cord switch will void any and all Warranties of the complete door.

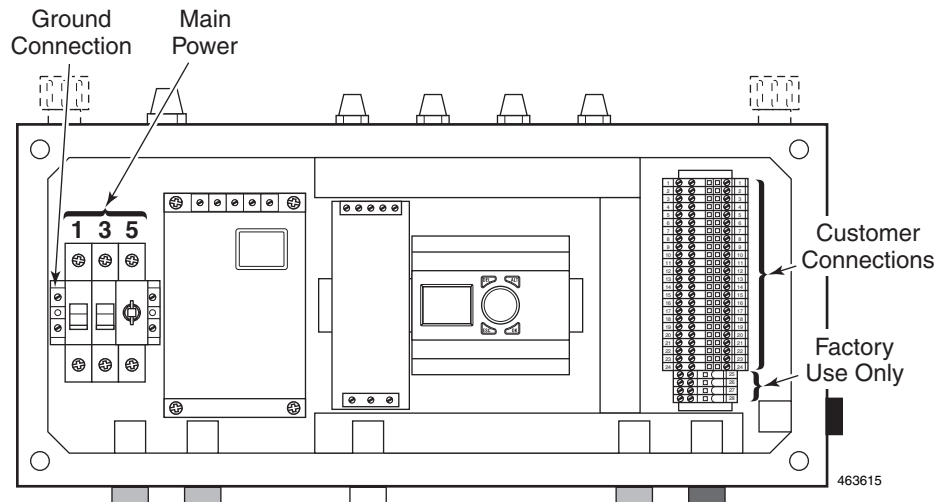

Figure 21

Installation Tip: Once power is connected, the door can be operated using the Test button. Provide temporary power to the door prior to the arrival of the installer. This will allow the installer to complete the door installation and adjustments prior to an electrician performing the permanent wiring, thus saving the installer a return trip.

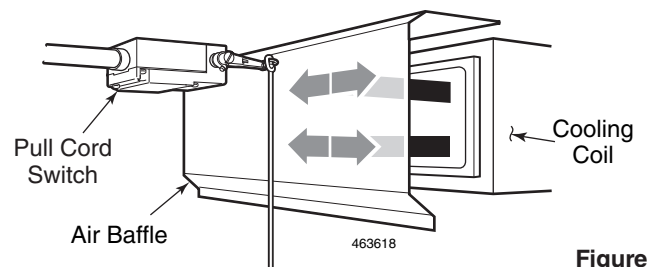

Figure 22

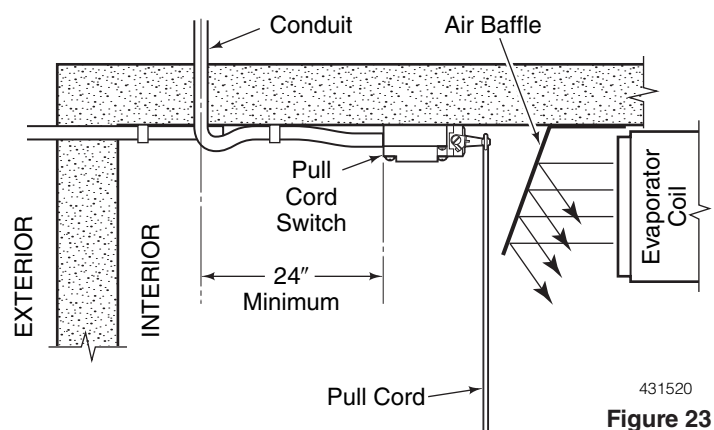

Figure 23

Pull Cord Installation (Continued)

3. Locate the pull cord switch away from the door and out of the way of lift trucks and loads. It is most common to locate one pull cord at the interior and one at the exterior of the door opening.
4. Fasten the switch securely to the wall or ceiling and attach the pull cord to the switch arm. Allow the pull cord to hang straight; do not use guide rings or screw eyes to reposition the cord. Such items can hinder operation of the cord or switch.

Pull Cord Wiring

5. Install conduit and wire (according to code) from the pull switch through the external wiring port of the Control Panel. See Figures 24 and 25.
6. Remove the covers from the pull cord switches.
7. Connect the wires of one of the pull cord switches to terminal blocks #5 and #9. See Figure 21.
8. Connect the wires of the other pull cord switch in parallel with the first one (shown) or to terminal blocks #6 and #10. Replace the Switch covers.
9. Seal the interior and exterior of conduit at all cooler penetrations. Seal the conduit at its attachment to the pull cord switch. Use watertight fittings.

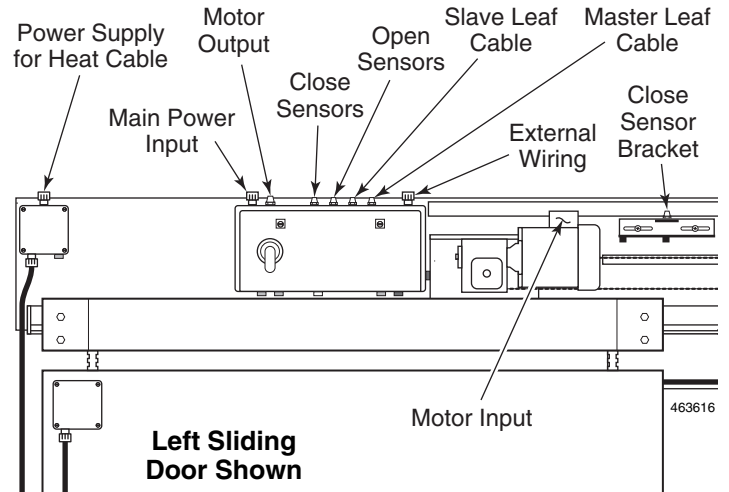

Figure 24

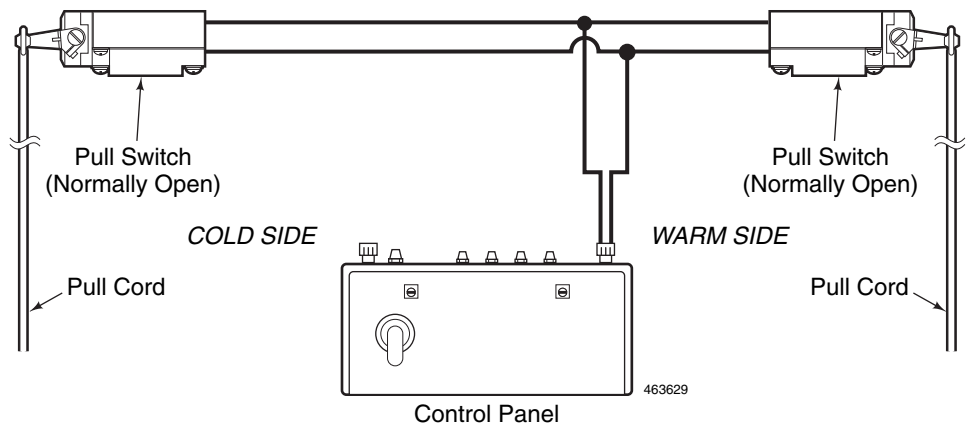

Figure 25

Other Input/Output Signals

Input devices other than a pull cord switch can be used to control the door. These devices include:

- Three-button stations
- Open and close switches
- Tap switches
- Magnetic loops
- Optical sensors
- Motion sensors
- Interlock signal
- Emergency stop

Output signals are:

- Interlock OUT
- Alarm

Connect Input/Output wires in a manner similar to the pull cord wires (above). Refer to the *Terminal Blocks* section of the *R-Plus Doors ICC-5 Operator Quick Reference* manual and to the *Input/Output Guidelines* sheets to know where and how to connect these devices. See Figure 21.

Installation Tip: Just as the pull cord switches must be protected from air currents, the Operator may require the same protection. Standard Operators are designed to be operated in above freezing environments. These Operators must be protected from cold air currents such as those from refrigeration coils. A low temperature Operator is available for below freezing environments.

Door Travel Adjustment

When shipped from the factory, the Door is preset with temporary Door Travel limits. Open the Door to check the limits and adjust as necessary. The Test pushbutton, on the side of the Control Panel, functions in the same manner as a Pull Cord switch. Use it to control the Door until the travel limits are verified or adjusted. See Figure 26.

1. Door travel limits are adjusted by sliding the Open and Close Sensor Brackets. One is located near the motor, the other near the idler sprocket (double idler sprocket on bi-parting doors). Lights on the Control Panel show sensor activation as the Magnet Slide passes a Sensor Bracket. If adjustment is necessary, proceed as follows: See Figure 27.

Adjust the Door Open travel limit (for Single and Bi-Parting Doors)

The stop locations (travel limits) will shift in the opposite direction the Sensor Bracket is moved. When properly adjusted, the leading edge of the door, in the Open position, is flush with the room opening.

1. With the Door in the full Open position, measure the distance the Door must move to reach the desired Open stop location. See Figure 28.
2. Loosen the Sensor Bracket and slide it the same distance, and the *opposite* direction, as the desired new Open position. See Figure 29.
3. Operate the Door through a complete Open/Close cycle to test the new Open stop location. Tighten the Sensor Bracket in place.

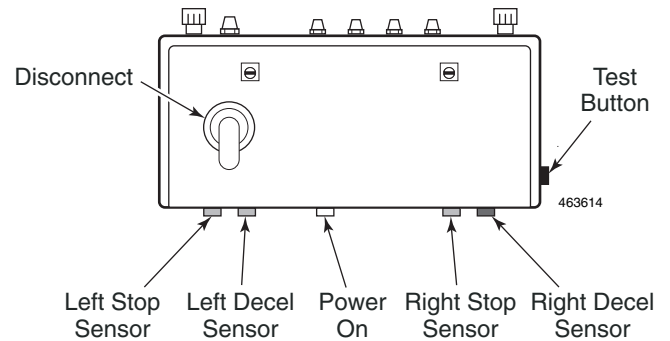

Figure 26

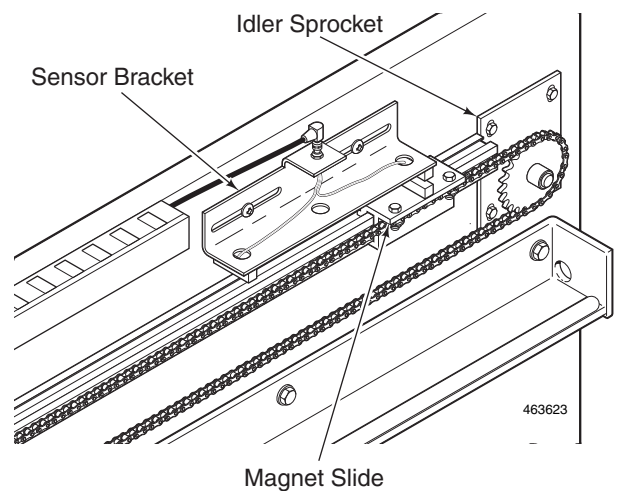

Figure 27

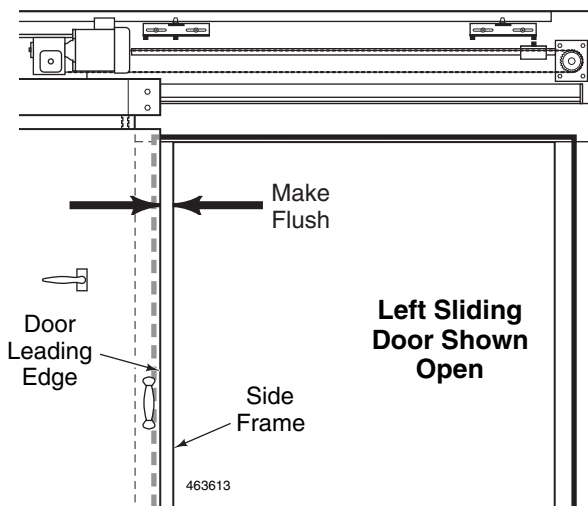

Figure 28

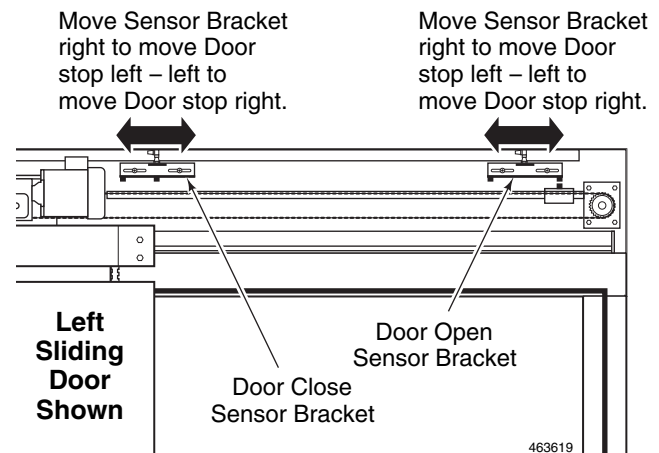

Figure 29

Adjust the Door Close travel limit

The Door Close Sensor Bracket on Single Sliding Doors is not used in the same fashion as it is used on Bi-Parting Doors. The procedure is different. Refer to the following section appropriate to your door type.

Single Doors

With the Door Open travel limit set, proceed in a similar manner to set the Door Close travel limit. In the closed position, a single door should be centered on the Side Frames with equal distance from the Door edge to the edge of the Side Frame. This will allow the Door to overlap the Side Frame Gasket equally.

See Figure 30.

The stop locations (travel limits) will shift in the opposite direction the Sensor Bracket is moved.

1. With the Door in the full Closed position, measure the distance the Door must move to reach the desired Closed stop location. See Figure 29.
2. Loosen the Sensor Bracket and slide it the same distance, and the *opposite* direction, as the desired new Closed position.
3. Operate the Door through a complete Open/Close cycle to test the new Closed stop location. Tighten the Sensor Bracket in place.

Bi-Parting Doors

Door closing sequence

- The Door starts slowing as it passes the Close Decel Sensor. See Figure 31.
- Door safety edge gets disabled. This happens just before the leading edges come into contact (or door movement will reverse) in order to limit exposure to pinch risk.
- After the travel speed slows, door leaves contact and stop moving. This happens before the Stop Sensor is reached so gasket pressure, between the leaves, will be maintained. (In normal bi-parting door operation, the Stop Sensor is being used for emergency stop only.)
- The Operator stops driving the door, but applies continuous pressure (at reduced power) for a positive gasket seal. A slight motor hum may be heard.

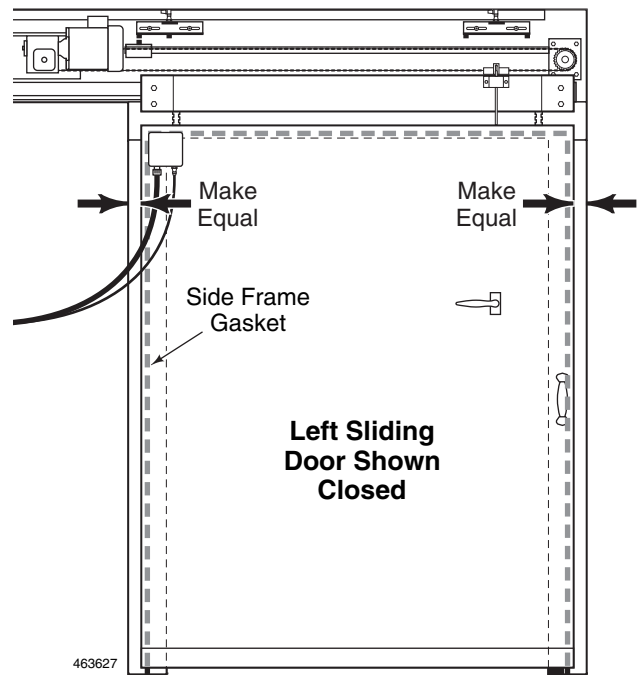

Figure 30

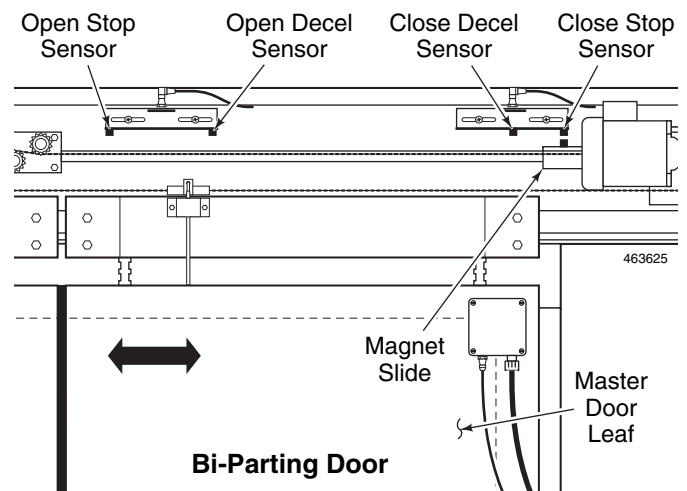

Figure 31

Bi-Parting Doors (Continued)

With the Door Open travel limit set, proceed in a similar manner to set the Door Close travel limit. A properly adjusted bi-parting door, in the closed position, will have 1/8" compression at the center gaskets. See Figure 32.

The stop locations (travel limits) will shift in the opposite direction the Sensor Bracket is moved.

1. Move the Sensor Bracket fully away from the motor. Close the Door. The Door will stop prior to contact of the leading edge gaskets. Measure the distance between the Door Hanger Channels. See Figure 33.
2. Loosen the Sensor Bracket and slide it toward the motor by one-half the distance, plus 1/2".
3. Operate the Door through a complete Open/Close cycle to test the new closing sequence.
 - Check the Control Panel; if the Close Stop Sensor red light is ON, the Stop Sensor has been reached and the Door has stopped too soon. Move the Sensor Bracket toward the motor and re-test. See Figure 34.
 - If the Door closes, then reverses immediately, the Sensor Bracket is too close to the Close location and the Safety Edge was still enabled when the Door leaves came into contact. Move the Sensor Bracket slightly away from the motor and re-test.
4. Once satisfied with the closing sequence and adjustment, verify the proper gasket compression and tighten the Sensor Bracket.

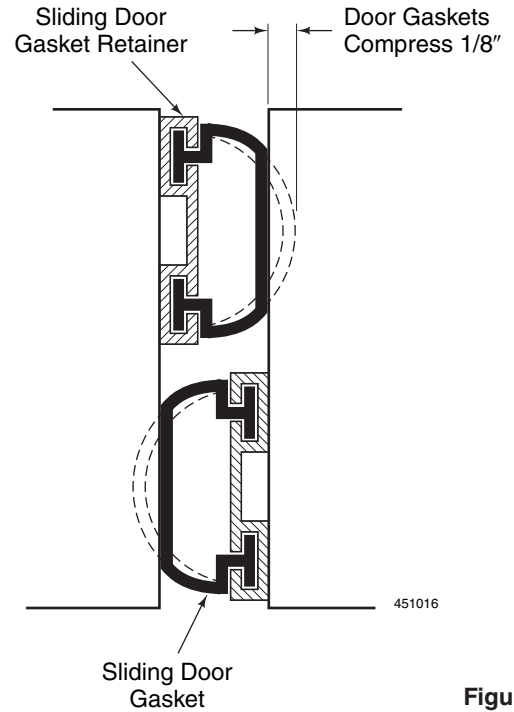

Figure 32

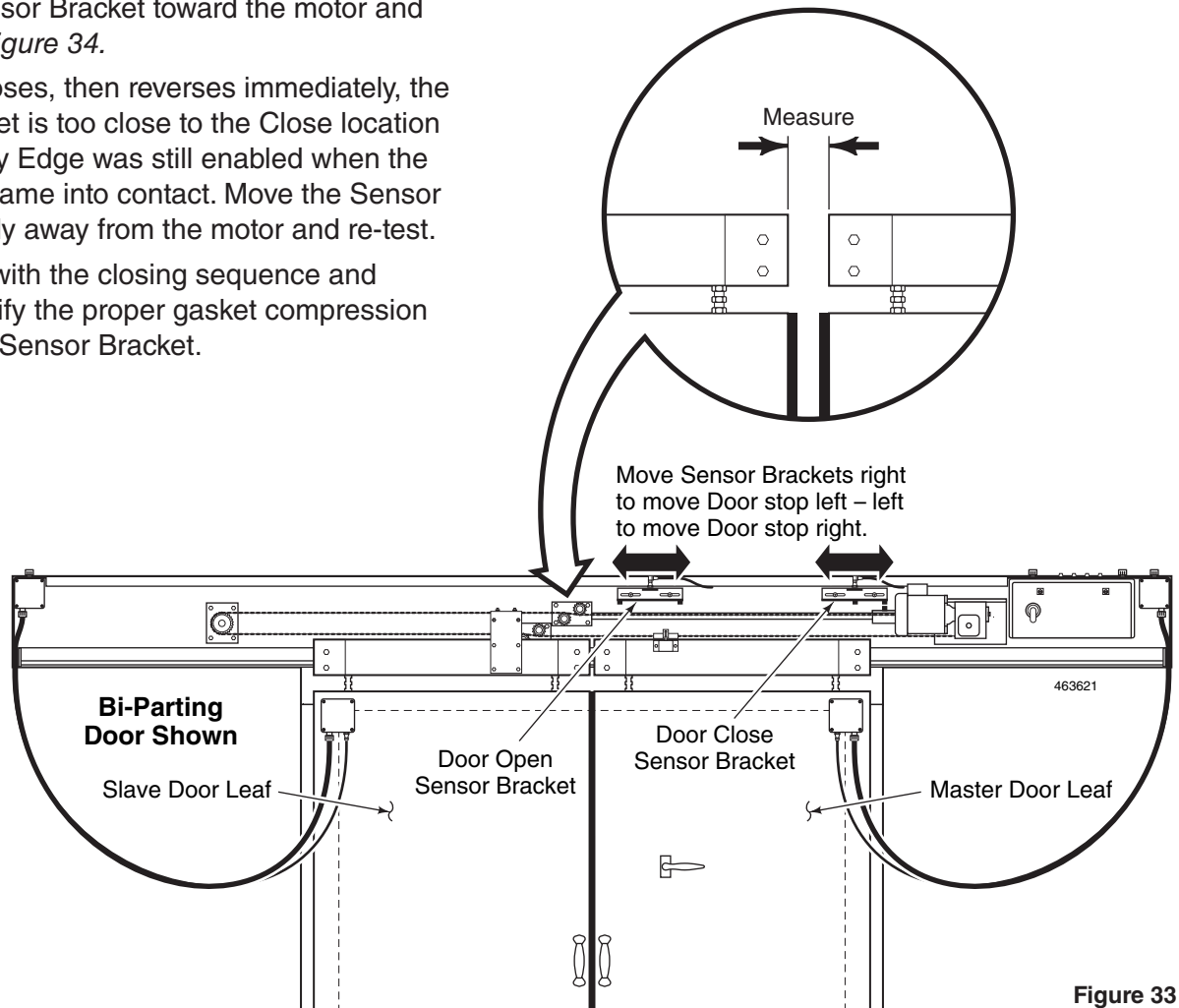

Figure 33

Test the Door travel limits

When both door travel limits have been set, open and close the door to test the operation.

1. Test run the door by using the Pull Cord, Remote Control, or Test pushbutton.
2. Note the position the door stops in both directions, and readjust the travel limits as necessary.

NOTE: If the door starts to close then stops and opens immediately, or closes fully and reopens immediately, the Door Safety Edge may be set too sensitive and must be adjusted.

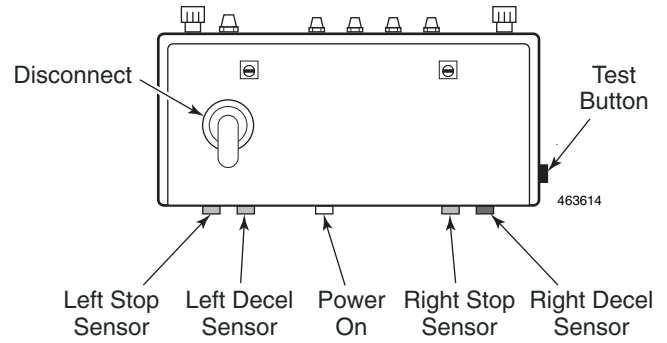

Figure 34

Adjust the Door Safety Edge

Locate the Door Leaf Junction Box. Remove the junction box cover plate. Optimum sensitivity can be achieved using a simple two step process.

See Figure 35.

1. With the power on and the Door open, insert a small screwdriver in the large plastic screw on the front side of the Air Switch (the side with the wire terminals). Turn the Screw out to *decrease* sensitivity or in to *increase* sensitivity.



WARNING: Turn the screw $\frac{1}{8}$ turn at a time and test the door (see below). Do not turn too far — the Air Switch can be damaged.

2. Test the sensitivity. Start the Door closing with the Pull Cord or Test pushbutton. Touch the Safety Edge with a tool to reverse the Door and verify the proper sensitivity. See Figure 36.

Test the Door travel limits and adjust as necessary.



CAUTION: The Door Safety Edge is disabled when the bi-parting doors reach the close stop location.

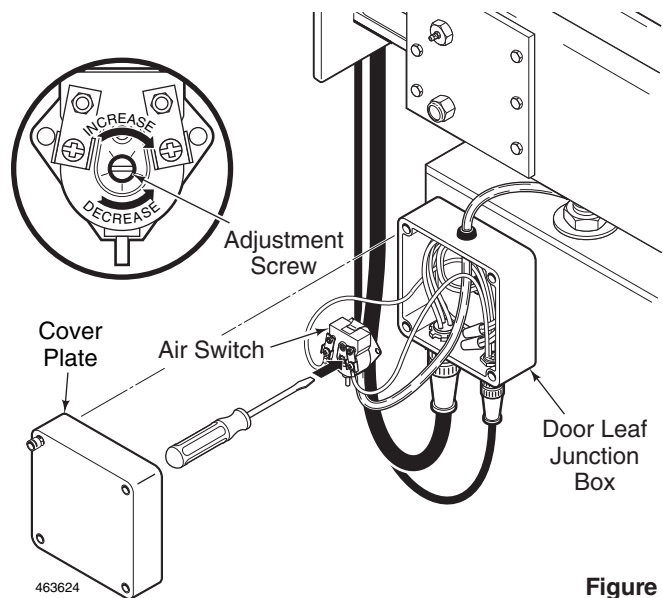

Figure 35

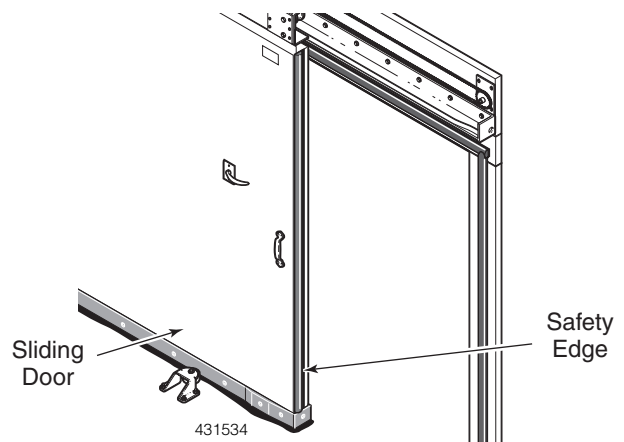

Figure 36

Door Auto-Close Function

The door is equipped with an Auto-Close function. When enabled, the auto-close timer starts when the door stops moving. When it reaches the end of a pre-set auto-close delay, the door closes automatically.

If equipped with the optional siren and/or strobe light alarm system, the alarm will activate 5 seconds prior to the start of the auto-close cycle. The alarm is always active when the door is closing. See Figure 37.

Two distinct auto-close functions are available:

- Auto-Close when the door is fully open
- and
- Auto-Close when the door is partially open.

By default the Auto-Close functions are disabled.

To enable the Auto-Close function, press Right Arrow (P3) on the Rocker button until the desired menu is selected. Use Arrow Down (P4) to select a time between 10 and 60 seconds. See below.

To disable the Auto-Close function, press the Right Arrow (P3) on the Rocker button until the desired menu is selected. Use Arrow Down (P4) to select a time less than 10 seconds. See below.



CAUTION: The Door will close when the time has elapsed. Do not block the Door.

To adjust the time delay:

1. Using the Rocker button, press Right Arrow (P3) until the desired menu is selected (FULL OPEN or PARTIAL OPEN). See Figure 39.
2. Press Arrow Down (P4) to select a value between 10 to 60 seconds. A single press will add 1 second. Press and hold to add time rapidly. At 60 seconds the counter will start again at zero.
3. When done, and if desired, press Right Arrow (P3) several times to return to the default screen. The menu system will automatically return to the default screen two minutes after having moved away from it.

Door Cycle Counter

To see the number of cycles the operator has performed, press Right Arrow (P3) until the TOTAL CYCLES screen is displayed. The first row of numbers (H) indicates 10,000s. The second row (L) indicates ones. In the example shown, the total count is 20,234. See Figure 40.

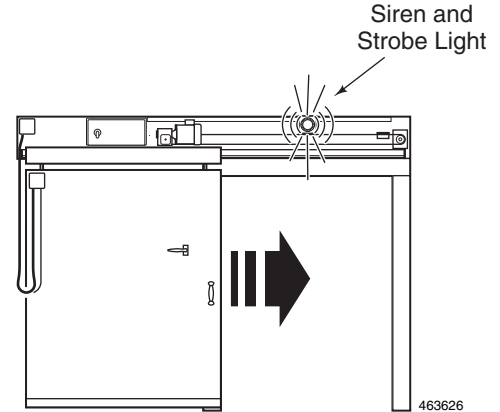

Figure 37

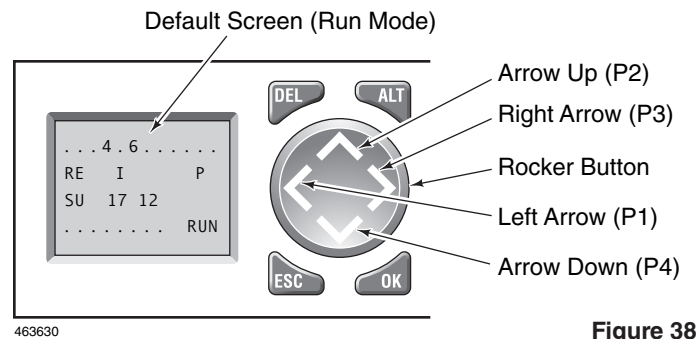

Figure 38

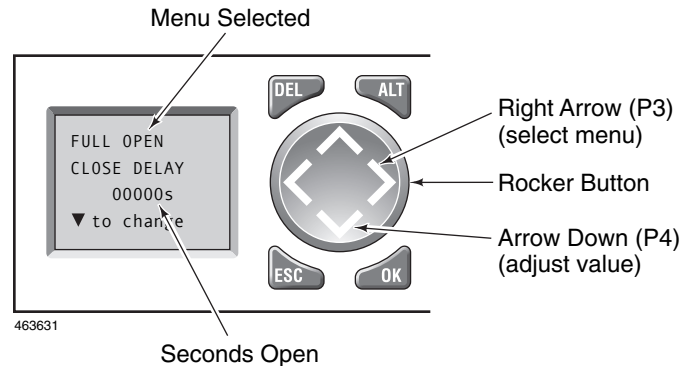

Figure 39

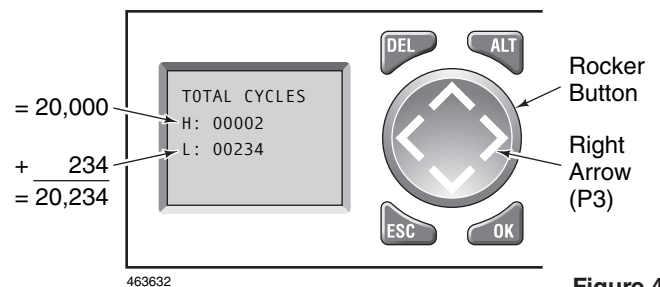

Figure 40

PERIODIC MAINTENANCE

Lubrication

Perform the following tasks on a regular basis. The frequency will be determined by the operating conditions at the installation site. In no case should the frequency be greater than 5000 cycles.

1. Track Rollers – Grease axles as needed with food grade machinery grease type NLGI #2 (Mobilgrease FM102 or the equivalent).
2. Idler Sprocket – Grease as needed with food grade machinery grease NLGI #2 (Mobilgrease FM102).
3. Drive Chain – Lightly oil chain as needed with a suitable chain oil. Also check for proper tension.
4. Drive Chain Bullet Assembly – Silicone spray the pivot on the Release Latch and the internal tube for the Cable in the Cable Bracket. See *Figures 18 and 20*.
5. Safety Release Handle – Lightly spray pivot inside J-Box with silicone. Check release handle for free play.
6. Stay Rollers – Lightly spray oil impregnated bushings with silicone lube monthly.

Gaskets

1. Inspect the Bottom Neoprene Sweep Gasket for proper light-tight seal. Adjust or replace as needed.
2. Inspect the Sliding Door Gasket for proper 1/8" compression and light-tight seal. See *Figure 13*.

Track Rollers

1. Check for undue wear and proper alignment, tighten or replace if needed.

Door Safety Edge

1. Check periodically for proper operation. Repair or replace as needed.

CAUTION: Some of the following troubleshooting procedures require testing inside the control box. This should be performed by a qualified service technician only. Testing should be limited to checking circuit breakers and inspecting PLC I/O lights. Tampering with other wiring or components in the control box will void your warranty.

Maintenance Counter

When the Door has completed 5000 cycles, the message "TIME FOR MAINTENANCE" will appear on the PLC screen. Perform the above inspections and lubrications, then reset the Counter.

1. To reset the Counter, with the TIME FOR MAINTENANCE message displayed on the screen, press and hold Arrow Up (P2) for 4 seconds. The counter will reset and the message will erase.

See *Figure 41*.

The maintenance counter can be accessed any time to check the number of cycles accrued. Press Right Arrow (P3) several times until the CYCLES SINCE MAINTENANCE screen is displayed. See *Figure 42*.

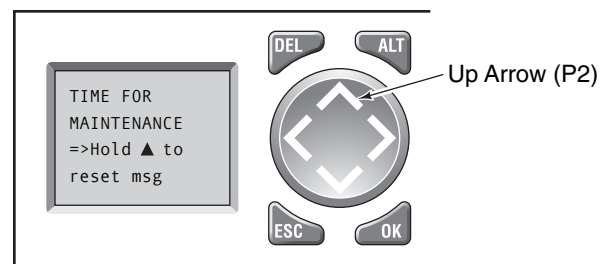

Figure 41

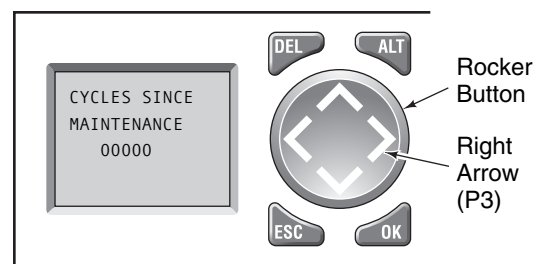

Figure 42

WARRANTY

Imperial Manufacturing Ice Cold Coolers, Inc. warrants to the original purchaser of its products that the foamed-in-place urethane panels purchased from Imperial Manufacturing Ice Cold Coolers, Inc. are free from defects in material and workmanship for a period of five (5) years and a one (1) year warranty on all other parts from the date of original shipment under normal use and service. This warranty is limited to replacement (FOB Imperial) of malfunctioning parts and does not include damage resulting from accident or malicious misuse.

Exclusive Warranty - No Implied Warranties

This written and expressed warranty is the only warranty provided by Imperial Manufacturing Ice Cold Coolers, Inc. on the products they sell.

All warranties, which might otherwise be implied in this contract, are hereby excluded from this contract. This includes excluding the implied warrant of merchantability and fitness for a particular purpose. There are no warranties, which extend beyond the description of the warranties on the face hereof.

Exclusive Remedies

The buyer's exclusive remedy under this warranty or for the breach of this warranty shall be the repair or the replacement of the defective part by Imperial Manufacturing Ice Cold Coolers, Inc. Imperial Manufacturing Ice Cold Coolers, Inc. shall repair, or at its option replace, F.O.B. the factory, any part of the product which their examination shall disclose, to their satisfaction, to be defective.

No other remedy, including rejection of goods, revocation of acceptance, nor consequential damages for personal or property damage, nor incidental damages shall be allowed to the buyer of this product.

Hardware, Electrical Components and Accessories

All hardware, electrical components and accessories are warranted to be free of defects in materials and workmanship under normal use and service for one (1) year from the date of original shipment.

Voidability of Warranty

This warranty is void and of no force or effect, and the buyer shall have no expressed or implied warranties against defects, nor remedies for defects, if any of the following events occur:

- The door(s) are not installed within 120 days of original shipment
- The door(s) are not installed by a factory authorized installer
- The door(s) have been subjected to improper installation, misuse, abuse, neglect, alteration, accident, fire, flood, earthquake or other natural disasters.

This warranty does not include food or product loss, labor or transportation charges for replacement or repair of defective parts. This warranty is nontransferable. The original purchaser is the firm or individual to whom Imperial Manufacturing Ice Cold Coolers, Inc. originally sold this product.

*R-Plus doors are designed to operate within the following temperature ranges:

Interior Freezer: -10 degrees F. to 32 degrees F.

Interior Cooler: 33 degrees F. to 100 degrees F.

Exterior Ambient Temperature: 65 deg F. to 80 deg F.

WE MUST BE NOTIFIED UPON PLACEMENT OF THE ORDER IF OPERATING TEMPERATURES ARE OUTSIDE THE ABOVE NORMAL DESIGN TEMPERATURES TO PROPERLY DESIGN THE PRODUCT OR THE WARRANTY MAY BE VOIDED.

R-PLUS

COLD STORAGE DOORS

A Division of Imperial Manufacturing, Inc.

2271 NE 194th • Portland, Oregon 97230

Toll Free (800) 238-4093 • Phone (503) 665-5539

Fax (503) 665-2929 • www.RPlusDoors.com