



COLD STORAGE DOORS

A Division of Imperial Manufacturing

Phone: 503.665.5539

800.238.4093

Fax: 503.665.2929

www.imperialmfg.com

Job Number: _____

Job Name: _____

Date: _____

Quantity: _____

Horizontal Electric Sliding Door (Right Slide)

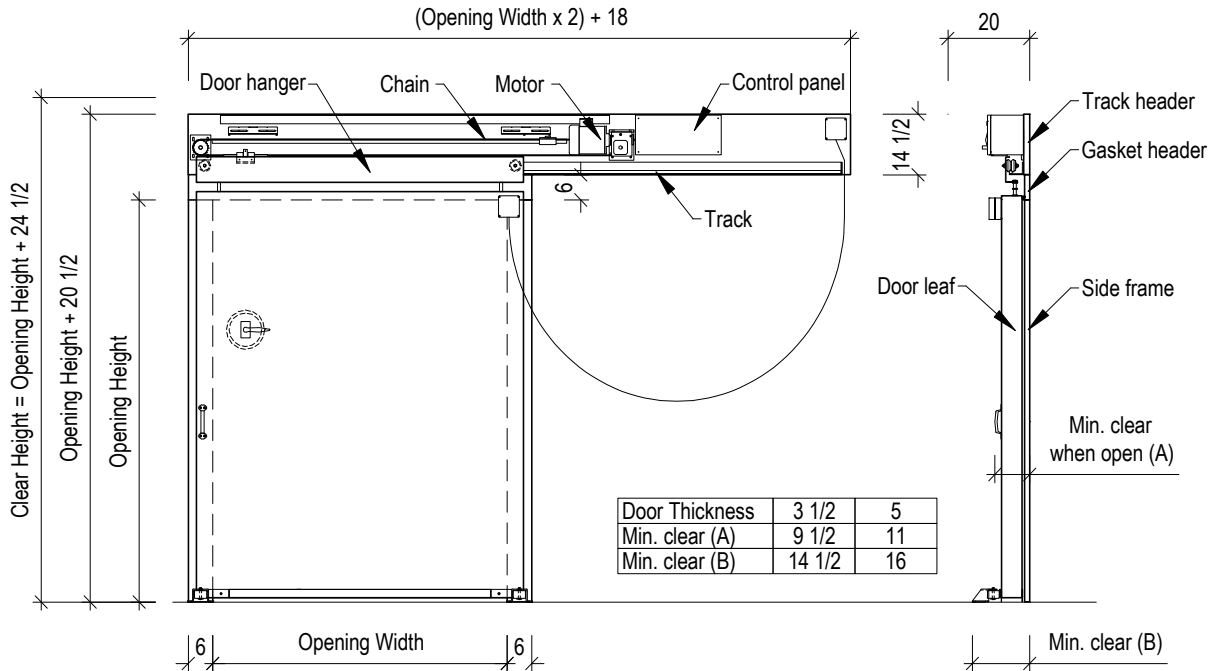

HSER_HORI05

Net Opening Width: _____ Height: _____	Door Type <input type="checkbox"/> Cooler <input type="checkbox"/> Freezer Temperature: _____ °F	Door Panel Thickness: <input type="checkbox"/> 3 1/2" <input type="checkbox"/> 5"	Exterior Finish / Kickplates <input type="checkbox"/> Smooth <input type="checkbox"/> Stucco <input type="checkbox"/> Steel Galvanized <input type="checkbox"/> Steel White <input type="checkbox"/> Aluminum <input type="checkbox"/> Aluminum White <input type="checkbox"/> Stainless Steel* _____ <input type="checkbox"/> Galvaneal* <input type="checkbox"/> Other _____ <input type="checkbox"/> Rigidized <input type="checkbox"/> Kickplates <input type="checkbox"/> Aluminum Diamond Tread <input type="checkbox"/> Galvanized <input type="checkbox"/> _____ *smooth only	Interior Finish / Kickplates <input type="checkbox"/> Smooth <input type="checkbox"/> Stucco <input type="checkbox"/> Steel Galvanized <input type="checkbox"/> Steel White <input type="checkbox"/> Aluminum <input type="checkbox"/> Aluminum White <input type="checkbox"/> Stainless Steel* _____ <input type="checkbox"/> Galvaneal* <input type="checkbox"/> Other _____ <input type="checkbox"/> Rigidized <input type="checkbox"/> Kickplates <input type="checkbox"/> Aluminum Diamond Tread <input type="checkbox"/> Galvanized <input type="checkbox"/> _____ *smooth only
Options <input type="checkbox"/> Lock Hasp w/ Safety Release <input type="checkbox"/> Breaker Handle <input type="checkbox"/> Heated Threshold <input type="checkbox"/> Double Frame & Header <input type="checkbox"/> Return Jamb Wall Thickness: _____ <input type="checkbox"/> View Window (in wicket door) <input type="checkbox"/> Non-Heated <input type="checkbox"/> Heated		Electric Operator <input type="checkbox"/> 208V <input type="checkbox"/> 220V <input type="checkbox"/> 460V <input type="checkbox"/> 1 ph <input type="checkbox"/> 3 ph <input type="checkbox"/> 60Hz <input type="checkbox"/> 50 Hz _____ Additional Pull Cords (2 standard) Radio Set: <input type="checkbox"/> Standard (operates 1 door) <input type="checkbox"/> Industrial (operates up to 4 doors) <input type="checkbox"/> Timer <input type="checkbox"/> Magnetic Loop <input type="checkbox"/> Microwave Sensor		

Charges will be assumed by buyer for changes or cancellations to work in process. Buyer hereby accepts responsibility for all sizes and dimensions. This order will not be processed until all acknowledgment forms are signed and returned.

Specifications Accepted by: _____

Date: _____



COLD STORAGE DOORS

A Division of Imperial Manufacturing
Phone: 503.665.5539
800.238.4093
Fax: 503.665.2929
www.imperialmfg.com

Job Number: _____

Job Name: _____

Date: _____

Quantity: _____

Horizontal Electric Sliding Door w/ Personnel Door (Right Slide, Right Hinge)

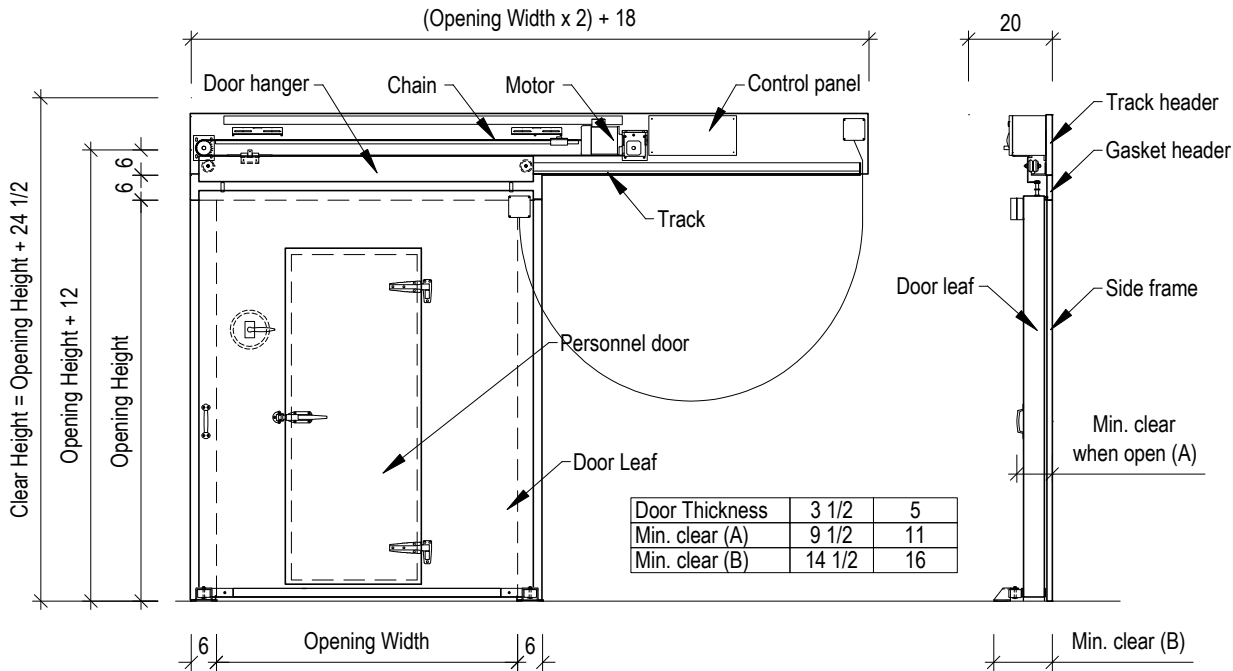

Table with 3 columns: Component, 3 1/2, 5. Rows: Door Thickness, Min. clear (A), Min. clear (B).

HSERP_HOR05

Form with sections: Net Opening, Door Type, Door Panel Thickness, Exterior Finish, Interior Finish, Options, Electric Operator, Wicket Door. Includes checkboxes for various features and specifications.

Charges will be assumed by buyer for changes or cancellations to work in process. Buyer hereby accepts responsibility for all sizes and dimensions. This order will not be processed until all acknowledgment forms are signed and returned.

Specifications Accepted by: _____

Date: _____



COLD STORAGE DOORS

A Division of Imperial Manufacturing

Phone: 503.665.5539

800.238.4093

Fax: 503.665.2929

www.imperialmfg.com

Job Number: _____

Job Name: _____

Date: _____

Quantity: _____

Horizontal Electric Sliding Door (Left Slide)

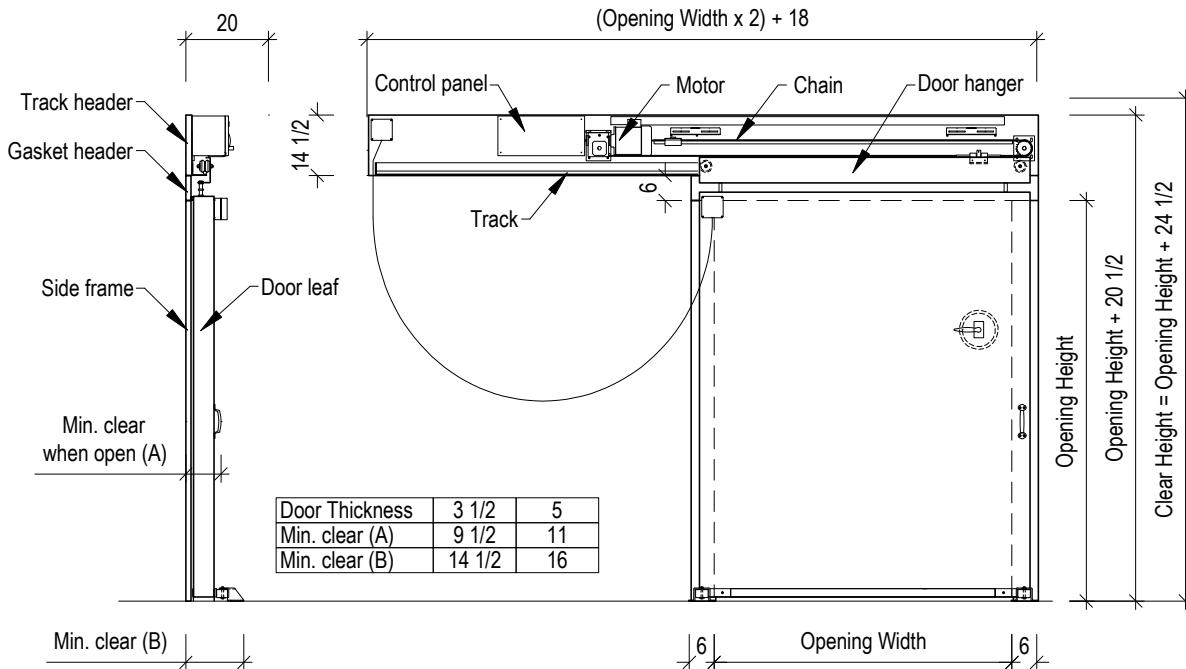

HSEL_HOR105

Net Opening Width: _____ Height: _____	Door Type <input type="checkbox"/> Cooler <input type="checkbox"/> Freezer Temperature: _____ °F	Door Panel Thickness: <input type="checkbox"/> 3 1/2" <input type="checkbox"/> 5"	Exterior Finish / Kickplates <input type="checkbox"/> Smooth <input type="checkbox"/> Stucco <input type="checkbox"/> Steel Galvanized <input type="checkbox"/> Steel White <input type="checkbox"/> Aluminum <input type="checkbox"/> Aluminum White <input type="checkbox"/> Stainless Steel* _____ <input type="checkbox"/> Galvaneal* _____ <input type="checkbox"/> Other _____ <input type="checkbox"/> Rigidized <input type="checkbox"/> Kickplates <input type="checkbox"/> Aluminum Diamond Tread <input type="checkbox"/> Galvanized <input type="checkbox"/> _____ *smooth only	Interior Finish / Kickplates <input type="checkbox"/> Smooth <input type="checkbox"/> Stucco <input type="checkbox"/> Steel Galvanized <input type="checkbox"/> Steel White <input type="checkbox"/> Aluminum <input type="checkbox"/> Aluminum White <input type="checkbox"/> Stainless Steel* _____ <input type="checkbox"/> Galvaneal* _____ <input type="checkbox"/> Other _____ <input type="checkbox"/> Rigidized <input type="checkbox"/> Kickplates <input type="checkbox"/> Aluminum Diamond Tread <input type="checkbox"/> Galvanized <input type="checkbox"/> _____ *smooth only
Options <input type="checkbox"/> Lock Hasp w/ Safety Release <input type="checkbox"/> Breaker Handle <input type="checkbox"/> Heated Threshold <input type="checkbox"/> Double Frame & Header <input type="checkbox"/> Return Jamb Wall Thickness: _____ <input type="checkbox"/> View Window (in wicket door) <input type="checkbox"/> Non-Heated <input type="checkbox"/> Heated	Electric Operator <input type="checkbox"/> 208V <input type="checkbox"/> 220V <input type="checkbox"/> 460V <input type="checkbox"/> 1 ph <input type="checkbox"/> 3 ph <input type="checkbox"/> 60Hz <input type="checkbox"/> 50 Hz _____ Additional Pull Cords (2 standard) Radio Set: <input type="checkbox"/> Standard (operates 1 door) <input type="checkbox"/> Industrial (operates up to 4 doors) <input type="checkbox"/> Timer <input type="checkbox"/> Magnetic Loop <input type="checkbox"/> Microwave Sensor			

Charges will be assumed by buyer for changes or cancellations to work in process. Buyer hereby accepts responsibility for all sizes and dimensions. This order will not be processed until all acknowledgment forms are signed and returned.

Specifications Accepted by: _____

Date: _____



COLD STORAGE DOORS

A Division of Imperial Manufacturing

Phone: 503.665.5539

800.238.4093

Fax: 503.665.2929

www.imperialmfg.com

Job Number: _____

Job Name: _____

Date: _____

Quantity: _____

Horizontal Electric Sliding Door w/ Personnel Door (Left Slide, Left Hinge)

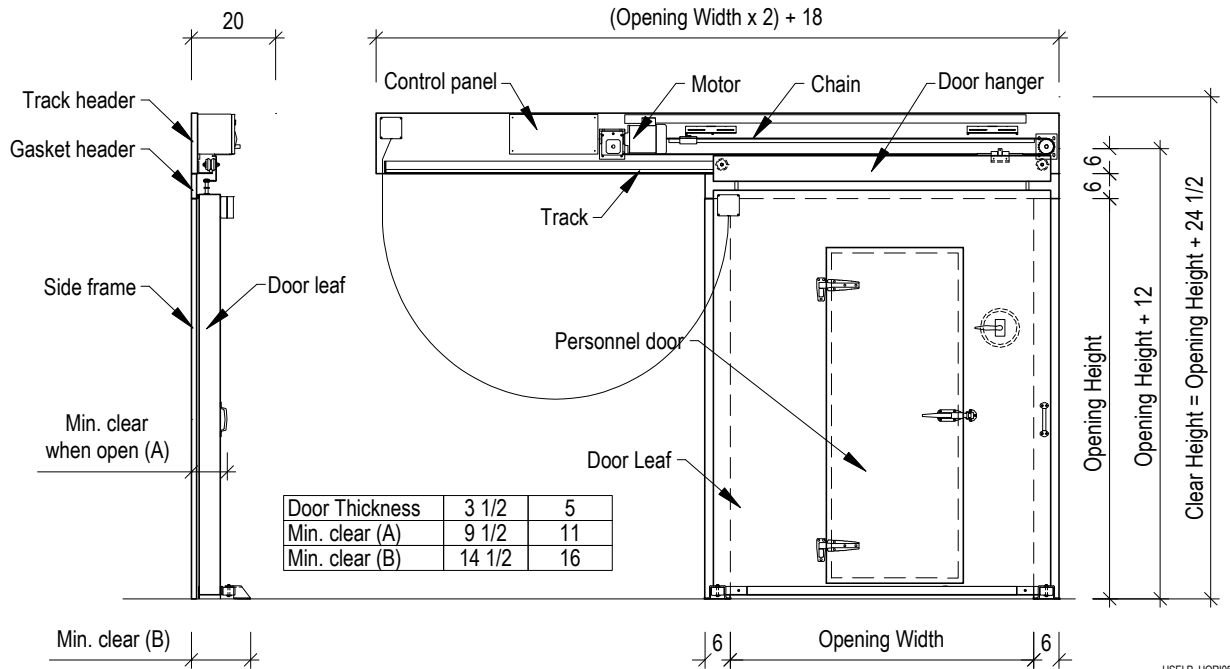

HSELP_HORI05

Net Opening Width: _____ Height: _____	Door Type <input type="checkbox"/> Cooler <input type="checkbox"/> Freezer Temperature: _____ °F	Door Panel Thickness: <input type="checkbox"/> 3 1/2" <input type="checkbox"/> 5"	Exterior Finish <input type="checkbox"/> Smooth <input type="checkbox"/> Stucco <input type="checkbox"/> Steel Galvanized <input type="checkbox"/> Steel White <input type="checkbox"/> Aluminum <input type="checkbox"/> Aluminum White <input type="checkbox"/> Stainless Steel* _____ <input type="checkbox"/> Galvaneal* _____ <input type="checkbox"/> Other _____ <input type="checkbox"/> Rigidized <input type="checkbox"/> Kickplates <input type="checkbox"/> Aluminum Diamond Tread <input type="checkbox"/> Galvanized <input type="checkbox"/> _____ *smooth only	Interior Finish <input type="checkbox"/> Smooth <input type="checkbox"/> Stucco <input type="checkbox"/> Steel Galvanized <input type="checkbox"/> Steel White <input type="checkbox"/> Aluminum <input type="checkbox"/> Aluminum White <input type="checkbox"/> Stainless Steel* _____ <input type="checkbox"/> Galvaneal* _____ <input type="checkbox"/> Other _____ <input type="checkbox"/> Rigidized <input type="checkbox"/> Kickplates <input type="checkbox"/> Aluminum Diamond Tread <input type="checkbox"/> Galvanized <input type="checkbox"/> _____ *smooth only
Options <input type="checkbox"/> Lock Hasp w/ Safety Release <input type="checkbox"/> Breaker Handle <input type="checkbox"/> Heated Threshold <input type="checkbox"/> Double Frame & Header <input type="checkbox"/> Return Jamb Wall Thickness: _____ <input type="checkbox"/> View Window (in wicket door) <input type="checkbox"/> Non-Heated <input type="checkbox"/> Heated	Electric Operator <input type="checkbox"/> 208V <input type="checkbox"/> 220V <input type="checkbox"/> 460V <input type="checkbox"/> 1 ph <input type="checkbox"/> 3 ph <input type="checkbox"/> 60Hz <input type="checkbox"/> 50 Hz _____ Additional Pull Cords (2 Std) Radio Set: <input type="checkbox"/> Standard (operates 1 door) <input type="checkbox"/> Industrial (operates up to 4 drs) <input type="checkbox"/> Timer <input type="checkbox"/> Magnetic Loop <input type="checkbox"/> Microwave Sensor	Wicket Door Width: _____ Height: _____ <input type="checkbox"/> Heat Cable <input type="checkbox"/> "D" Gasket <input type="checkbox"/> Magnetic Gasket <input type="checkbox"/> (_____) Hinges <input type="checkbox"/> Latch/Strike <input type="checkbox"/> Inside Release <input type="checkbox"/> Closer <input type="checkbox"/> Cylinder Lock <input type="checkbox"/> Locking Bar		

Charges will be assumed by buyer for changes or cancellations to work in process. Buyer hereby accepts responsibility for all sizes and dimensions. This order will not be processed until all acknowledgment forms are signed and returned.

Specifications Accepted by: _____

Date: _____



COLD STORAGE DOORS

A Division of Imperial Manufacturing

Phone: 503.665.5539

800.238.4093

Fax: 503.665.2929

www.imperialmfg.com

Job Number: _____

Job Name: _____

Date: _____

Quantity: _____

Horizontal Electric Biparting Sliding Door

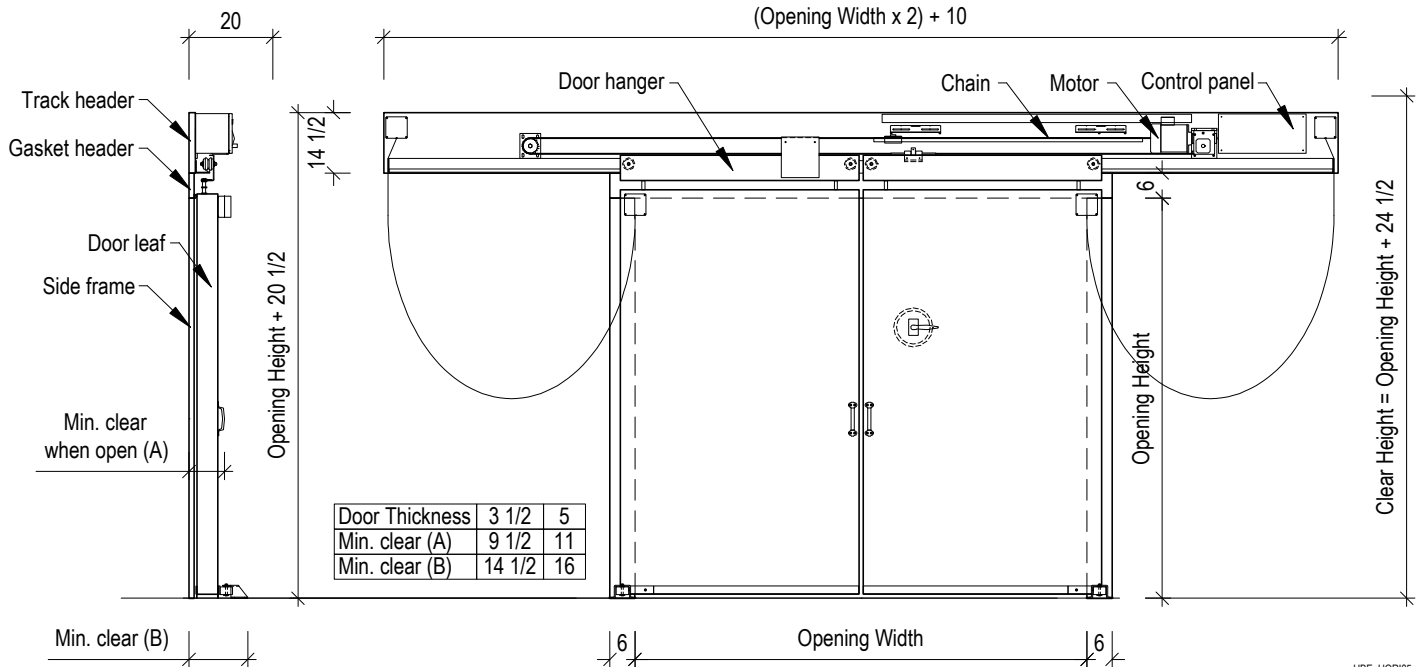

HBE_HOR105

Net Opening Width: _____ Height: _____	Door Type <input type="checkbox"/> Cooler <input type="checkbox"/> Freezer Temperature: _____ °F	Door Panel Thickness: <input type="checkbox"/> 3 1/2" <input type="checkbox"/> 5"	Exterior Finish <input type="checkbox"/> Smooth <input type="checkbox"/> Stucco <input type="checkbox"/> Steel Galvanized <input type="checkbox"/> Steel White <input type="checkbox"/> Aluminum <input type="checkbox"/> Aluminum White <input type="checkbox"/> Stainless Steel* _____ <input type="checkbox"/> Galvaneal* _____ <input type="checkbox"/> Other _____ <input type="checkbox"/> Rigidized <input type="checkbox"/> Kickplates <input type="checkbox"/> Aluminum Diamond Tread <input type="checkbox"/> Galvanized <input type="checkbox"/> _____ *smooth only	Interior Finish <input type="checkbox"/> Smooth <input type="checkbox"/> Stucco <input type="checkbox"/> Steel Galvanized <input type="checkbox"/> Steel White <input type="checkbox"/> Aluminum <input type="checkbox"/> Aluminum White <input type="checkbox"/> Stainless Steel* _____ <input type="checkbox"/> Galvaneal* _____ <input type="checkbox"/> Other _____ <input type="checkbox"/> Rigidized <input type="checkbox"/> Kickplates <input type="checkbox"/> Aluminum Diamond Tread <input type="checkbox"/> Galvanized <input type="checkbox"/> _____ *smooth only
Options <input type="checkbox"/> Lock Hasp w/ Safety Release <input type="checkbox"/> Breaker Handle <input type="checkbox"/> Heated Threshold <input type="checkbox"/> Double Frame & Header <input type="checkbox"/> Return Jambs Wall Thickness: _____ <input type="checkbox"/> View Window <input type="checkbox"/> Non-Heated <input type="checkbox"/> Heated		Electric Operator <input type="checkbox"/> 208V <input type="checkbox"/> 220V <input type="checkbox"/> 460V <input type="checkbox"/> 1 ph <input type="checkbox"/> 3 ph <input type="checkbox"/> 60Hz <input type="checkbox"/> 50 Hz _____ Additional Pull Cords (2 standard) Radio Set: <input type="checkbox"/> Standard (operates 1 door) <input type="checkbox"/> Industrial (operates up to 4 doors) <input type="checkbox"/> Timer <input type="checkbox"/> Magnetic Loop <input type="checkbox"/> Microwave Sensor _____		

Charges will be assumed by buyer for changes or cancellations to work in process. Buyer hereby accepts responsibility for all sizes and dimensions. This order will not be processed until all acknowledgment forms are signed and returned.

Specifications Accepted by: _____

Date: _____



COLD STORAGE DOORS

A Division of Imperial Manufacturing

Phone: 503.665.5539

800.238.4093

Fax: 503.665.2929

www.imperialmfg.com

Job Number: _____

Job Name: _____

Date: _____

Quantity: _____

Horizontal Electric Biparting Sliding Door w/ Personnel Door (Left Hinge)

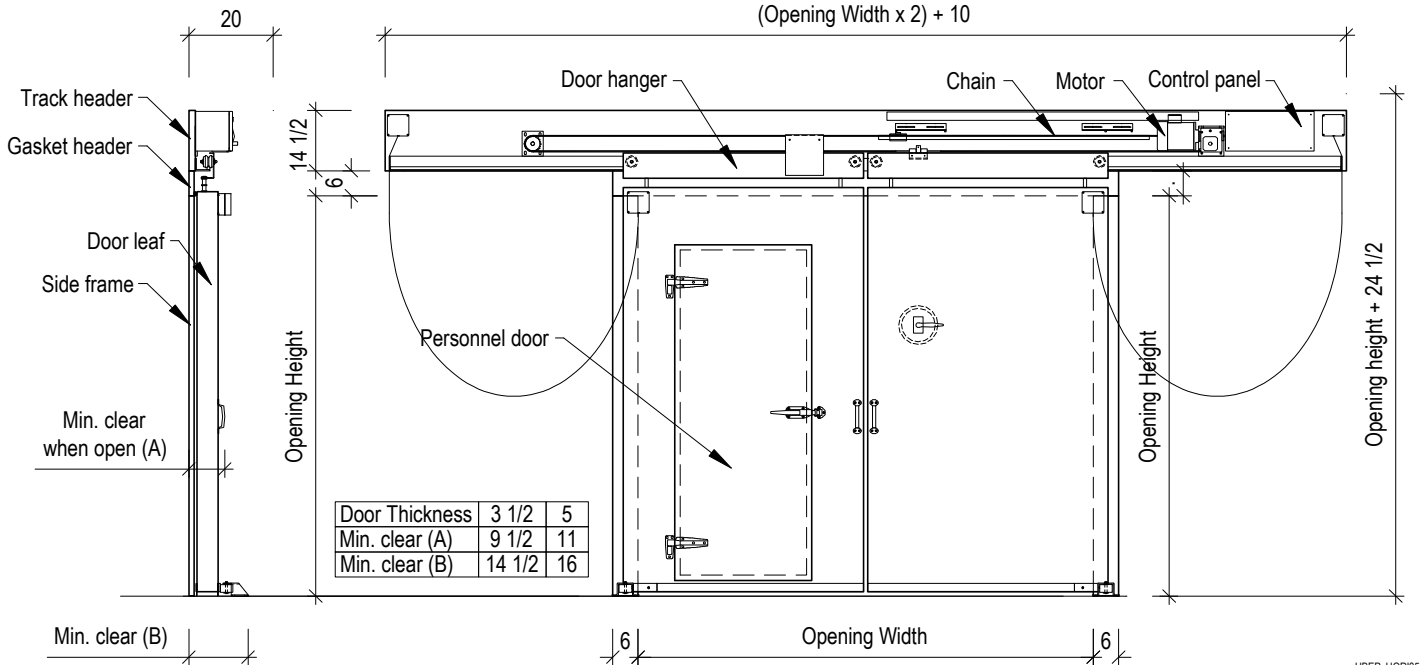

HBEP_HORI05

Net Opening Width: _____ Height: _____	Door Type <input type="checkbox"/> Cooler <input type="checkbox"/> Freezer Temperature: _____ °F	Door Panel Thickness: <input type="checkbox"/> 3 1/2" <input type="checkbox"/> 5"	Exterior Finish <input type="checkbox"/> Smooth <input type="checkbox"/> Stucco <input type="checkbox"/> Steel Galvanized <input type="checkbox"/> Steel White <input type="checkbox"/> Aluminum <input type="checkbox"/> Aluminum White <input type="checkbox"/> Stainless Steel* _____ <input type="checkbox"/> Galvaneal* _____ <input type="checkbox"/> Other _____ <input type="checkbox"/> Rigidized <input type="checkbox"/> Kickplates <input type="checkbox"/> Aluminum Diamond Tread <input type="checkbox"/> Galvanized <input type="checkbox"/> _____ *smooth only	Interior Finish <input type="checkbox"/> Smooth <input type="checkbox"/> Stucco <input type="checkbox"/> Steel Galvanized <input type="checkbox"/> Steel White <input type="checkbox"/> Aluminum <input type="checkbox"/> Aluminum White <input type="checkbox"/> Stainless Steel* _____ <input type="checkbox"/> Galvaneal* _____ <input type="checkbox"/> Other _____ <input type="checkbox"/> Rigidized <input type="checkbox"/> Kickplates <input type="checkbox"/> Aluminum Diamond Tread <input type="checkbox"/> Galvanized <input type="checkbox"/> _____ *smooth only
Options <input type="checkbox"/> Lock Hasp w/ Safety Release <input type="checkbox"/> Breaker Handle <input type="checkbox"/> Heated Threshold <input type="checkbox"/> Double Frame & Header <input type="checkbox"/> Return Jamb Wall Thickness: _____ <input type="checkbox"/> View Window <input type="checkbox"/> Non-Heated <input type="checkbox"/> Heated	Electric Operator <input type="checkbox"/> 208V <input type="checkbox"/> 220V <input type="checkbox"/> 460V <input type="checkbox"/> 1 ph <input type="checkbox"/> 3 ph <input type="checkbox"/> 60Hz <input type="checkbox"/> 50 Hz _____ Additional Pull Cords (2 Std) Radio Set: <input type="checkbox"/> Standard (operates 1 door) <input type="checkbox"/> Industrial (operates up to 4 drs) <input type="checkbox"/> Timer <input type="checkbox"/> Magnetic Loop <input type="checkbox"/> Microwave Sensor	Wicket Door Width: _____ Height: _____ <input type="checkbox"/> Heat Cable <input type="checkbox"/> "D" Gasket <input type="checkbox"/> Magnetic Gasket <input type="checkbox"/> (_____) Hinges <input type="checkbox"/> Latch/Strike _____ <input type="checkbox"/> Inside Release _____ <input type="checkbox"/> Closer _____ <input type="checkbox"/> Cylinder Lock _____ <input type="checkbox"/> Locking Bar _____		

Charges will be assumed by buyer for changes or cancellations to work in process. Buyer hereby accepts responsibility for all sizes and dimensions. This order will not be processed until all acknowledgment forms are signed and returned.

Specifications Accepted by: _____

Date: _____