

Bi-Part Horizontal Sliding Door

Manually operated ♦ Cooler or Freezer

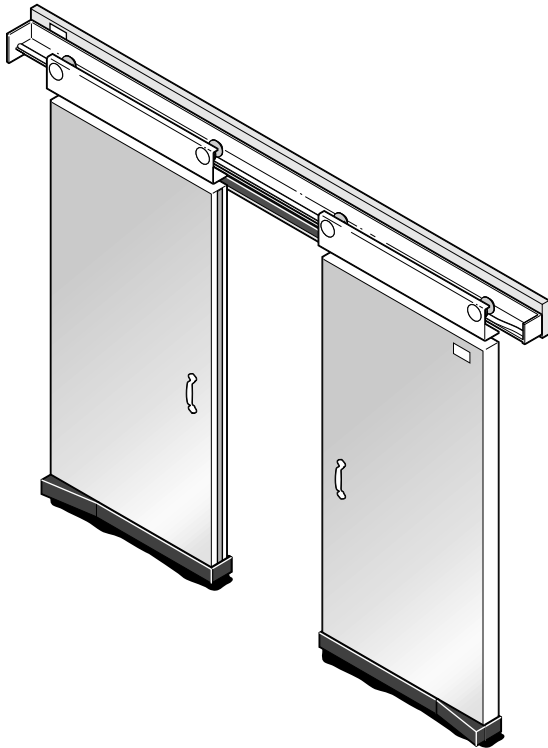

R-Plus Manual Sliding Doors are specially designed and custom built for high performance.

Features

- ♦ **QUIET OPERATION**
- ♦ **EASY INSTALLATION** - job-site adjustment flexibility
- ♦ **HEAVY DUTY TRACK ASSEMBLY & HARDWARE**
- ♦ **GUIDE SYSTEM** - ensures airtight seal and reduces gasket wear along the top and bottom
- ♦ **CLASS 1 CFC FREE FOAM INSULATION**
- ♦ **CAMLOCKED DOOR SECTIONS** - allows easy replacement in the event of damage
- ♦ **WATER RESISTANT SIDE FRAMES** - PVC insulated base
- ♦ **REPLACEABLE HEATER CABLE** - does not require removal of door from track
- ♦ **EASY GASKET REPLACEMENT**

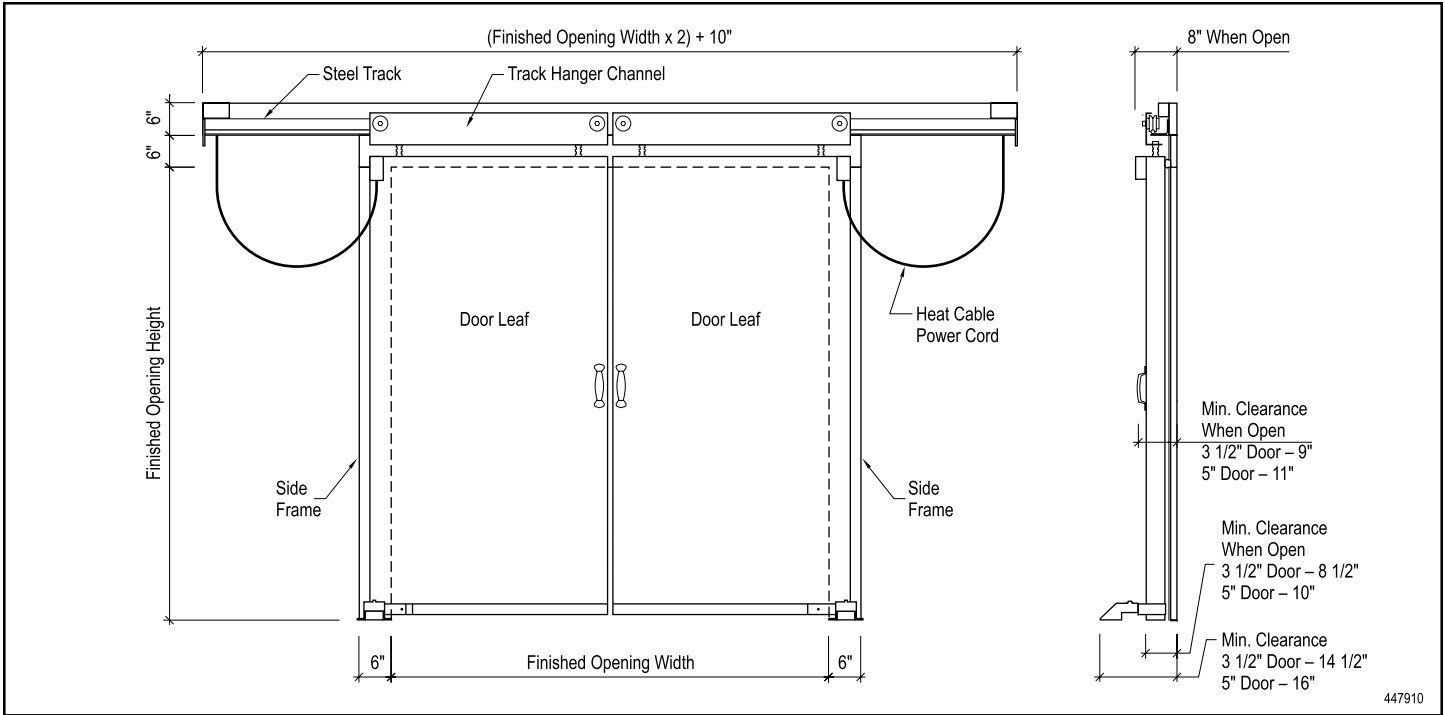

Architectural Specifications

Where indicated on plans, furnish R-Plus Cold Storage Doors to fit door opening size: _____ wide by _____ high, or as shown on architectural drawings.

Features

Door Sizes

- ♦ Standard sizes available up to 12' x 12' (contact factory for larger)
- ♦ All doors are custom made to order

Door Insulation

- ♦ CFC Free
- ♦ Class 1 foamed in place polyurethane
- ♦ ASTM E-84 flame spread less than 25, smoke developed less than 450
- ♦ Thickness 3.5" = R-28, 5" = R-40
- ♦ K Factor = .12

Panel Cladding

- ♦ Galvanized or white enameled steel (stucco, 26ga. or smooth, 24ga.)
- ♦ Stainless steel, 22ga.
- ♦ Sandstone, 26ga.
- ♦ Aluminum, .040

Side Frame Reinforcement

♦ Wood

Metal clad over sealed plywood for structural strength, 6" standard

♦ PVC

High density filled polyurethane for higher insulation, 4" standard

Gasket

- ♦ Replaceable, grease-resistant neoprene bulb-type seals
- ♦ Double sill neoprene wiper gasket

Door Heaters

on freezer models

- ♦ Replaceable UL approved pre-wired heater cable in door panel

Track System

- ♦ Heavy duty steel with corrosion protective hot dipped galvanized finish
- ♦ Heavy duty track hanger channel with V-groove wheels
- ♦ No barn door hardware

Warranty

- ♦ 5 yrs on panel, 2 yrs on parts against defects on material and workmanship

Optional Features

- ♦ Return jambs
- ♦ Double frame and header (mirror casing)
- ♦ Locking provision with safety release
- ♦ Tamper proof fasteners
- ♦ Triple pane windows, heated or non-heated 14" x 14" standard (please contact factory for other sizes)
- ♦ Hood for track
- ♦ Kick plates - 16 ga. galvanized steel, 18 ga. stainless steel and diamond plate aluminum
- ♦ Meat rail track port
- ♦ **Corrosion resistant package** - all stainless steel components and powder coated hardware
- ♦ **Power wash down package** - stainless steel and IP 66 rated mechanical components

In line with our commitment to improvement and engineering development, we reserve the right to change specifications or details without notice or obligation.

