

High Lift Vertical Door

Manual operated ♦ Cooler or Freezer

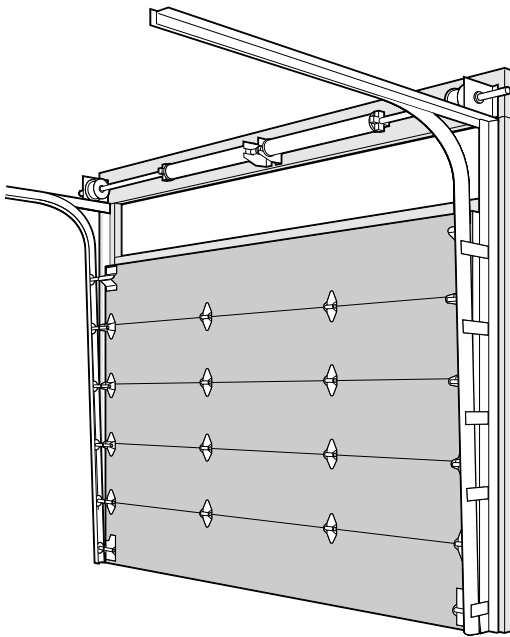

R-Plus Manual Vertical Doors are specially designed and custom built for high performance.

Features

- ♦ **QUIET OPERATION**
- ♦ **EASY INSTALLATION** - job-site adjustment flexibility
- ♦ **HEAVY DUTY TRACK ASSEMBLY & HARDWARE**
- ♦ **CLASS 1 CFC FREE FOAM INSULATION**
- ♦ **WATER RESISTANT SIDE FRAMES** - PVC insulated base
- ♦ **BOTTOM SAFETY EDGE** - provides instant stop and reverse upon contact
- ♦ **TORSION SPRING COUNTERBALANCE** - rated at 20,000 cycles
- ♦ **HEAT CABLES** - freezer models have cables at all outer edges and between sections of door panels
- ♦ **EASY GASKET REPLACEMENT**
- ♦ **ADJUSTABLE HIGH LIFT AREA** - allows door to be ordered with maximum clearance for each individual site

Architectural Specifications

Where indicated on plans, furnish R-Plus Cold Storage Doors to fit door opening size: _____ wide by _____ high, or as shown on architectural drawings.

Features

Door Sizes

- ♦ Standard sizes available up to 12' x 12' (contact factory for larger)
- ♦ All doors are custom made to order

Door Insulation

- ♦ CFC Free
- ♦ Class 1 foamed in place polyurethane
- ♦ ASTM E-84 flame spread less than 25, smoke developed less than 450
- ♦ Thickness 3.5" = R-28, 5" = R-40
- ♦ K Factor = .12

Panel Cladding

- ♦ Galvanized or white enameled steel (stucco, 26ga. or smooth, 24ga.)
- ♦ Stainless steel, 22ga.
- ♦ Sandstone, 26ga.
- ♦ Aluminum, .040

Side Frame Reinforcement

- ♦ **Wood**
Metal clad over sealed plywood for structural strength, 6" standard

Gasket

- ♦ Replaceable, grease-resistant neoprene bulb-type seals
- ♦ Foam gasket between door sections

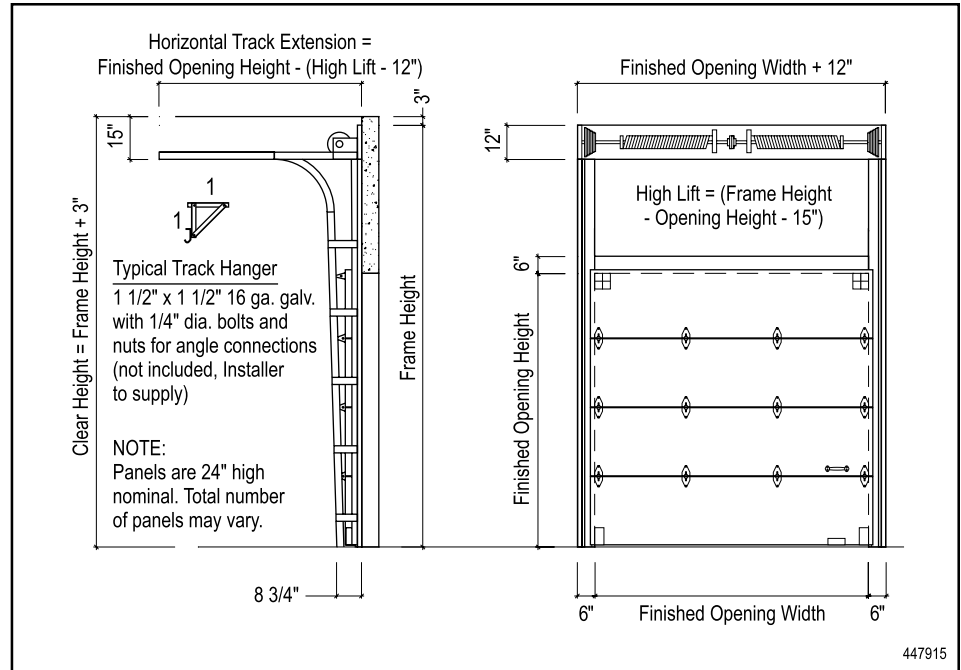

Door Heaters

on freezer models

- ♦ Replaceable UL approved heat cable pre-wired to all four sides of each panel

Track System

- ♦ Heavy duty steel with corrosion protective hot dipped galvanized finish
- ♦ Pre-mounted to side frames

Safety equipment

- ♦ Pre-wired pneumatic safety edge along the bottom of door for instant stop and reverse upon contact
- ♦ Door latch with padlock provision

Warranty

- ♦ 5 yrs on panel, 2 yrs on parts against defects on material and workmanship

Optional Features

- ♦ Double frame and header (mirror casing)
- ♦ Return jambs
- ♦ Triple pane windows, heated or non-heated 14" x 14" standard (please contact factory for other sizes)
- ♦ Track cover and outdoor hood
- ♦ Kick plates - 16 ga. galvanized steel, 18 ga. stainless steel and diamond plate aluminum
- ♦ Tamper proof fasteners
- ♦ Heated control panel for doors mounted on interior of freezers
- ♦ **Power wash down package** - stainless steel finish, NEMA 4X control box and electrical components, IP 66 rated mechanical components

In line with our commitment to improvement and engineering development, we reserve the right to change specifications and details without notice or obligation.

